

Series		Description	Size				Mounting		Operation		Page		
Parker	Denison		06	10	06	10	25	32	Subplate	Screw-in		Direct	Pilot
		Parker Standard DIN / ISO	06	10	06	10	25	32	Subplate	Screw-in	Direct	Pilot	
		Pressure relief valves, manual operation											
VS	–	For high secondary pressure			•				•		•		4-3
VB	–				•	•			•		•		4-7
VBV	–	For high secondary pressure			•	•			•		•	•	4-13
EVSA	–	With German certificate (TÜV)	•	•						•	•		4-19
R/RS	R4V/R6V				•	•	•		•			•	4-23
DSDU	–				•	•	•		•			•	4-35
		Pressure relief valves, proportional operation											
RE06M*W	4VP01	For high secondary pressure			•				•		•		4-39
RE06M*T	–				•				•		•		4-43
RE*W	R4V/R6V					•	•	•	•			•	4-49
RE*T	R4V/R6V					•	•	•	•			•	4-57
VBV*K	–				•	•			•			•	4-67
		Unloading and sequence valves, manual operation											
UR/US	R4U					•	•	•	•			•	4-73
S	R4S					•	•	•	•			•	4-83
		Pressure reducing valves, manual operation											
VM	–				•				•		•		4-87
PR	R4R					•	•	•	•			•	4-93
		Pressure reducing valves, proportional operation											
VMY	–				•				•			•	4-97
PE*W	R4R					•	•	•	•			•	4-103
		Accessories											
		Plug-in connectors Mounting patterns											4-109

More check valves are presented in the following chapters:

- Chapter 7: Sandwich Valves
- Chapter 8: Slip-In Cartridge Valves
- Chapter 9: SAE Flange Valves
- Chapter 10: Valves for Pipe Mounting

The pressure relief valve VS*06 is a direct operated spool valve for subplate mounting with internal drain to port T. The connection and function is according to ISO 6264.

Function

- Spool type valve
- Subplate mounting according to ISO 6264
- 5 pressure stages
- 2 adjustment modes
- Gauge port

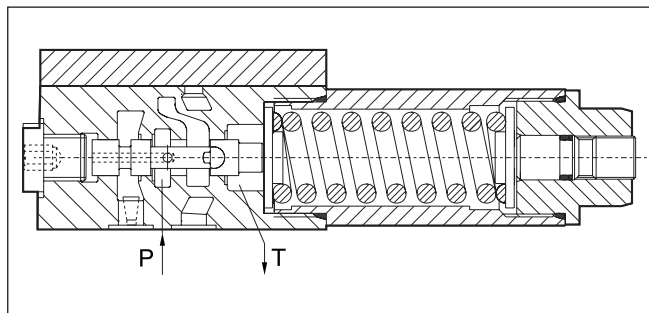
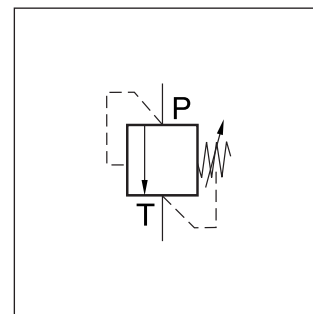

4

Ordering code

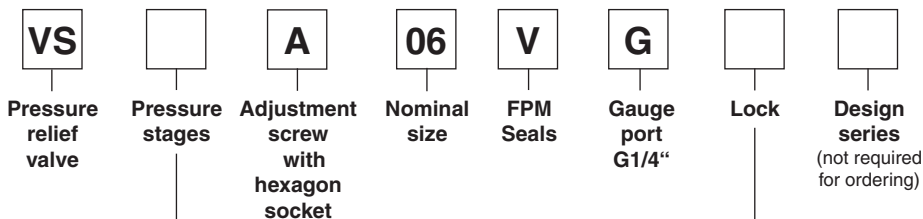

Code	Pressure stages
025	up to 25 bar
064	up to 64 bar
160	up to 160 bar
210	up to 210 bar
350	up to 350 bar

Code	Lock
omit	Normal
Z *	DIN lock

Bold letters = Short-term availability

* not pictured

Technical data

General		
Design		Direct operated relief valves spool type
Nominal size		DIN NG06 / CETOP03 / NFPA D03
Interface		Subplate mounting according to ISO 6264
Mounting position		unrestricted
Ambient temperature	[°C]	-20...+80
Weight	[kg]	1.3
Hydraulics		
Max. operating pressure	[bar]	Port P 350, Port T depressurized
Pressure stages	[bar]	25, 64, 160, 210, 350
Nominal flow	[l/min]	25
Fluid		Hydraulic oil according to DIN 51524...525
Fluid temperature	[°C]	Recommended +30...+50, permitted -20...+70
Viscosity permitted	[cSt] / [mm²/s]	20...380
recommended	[cSt] / [mm²/s]	30...50
Filtration		ISO 4406 (1999); 18/16/13

VS_UK.INDD CM



p/Q performance curves

Pressure stage 25 bar

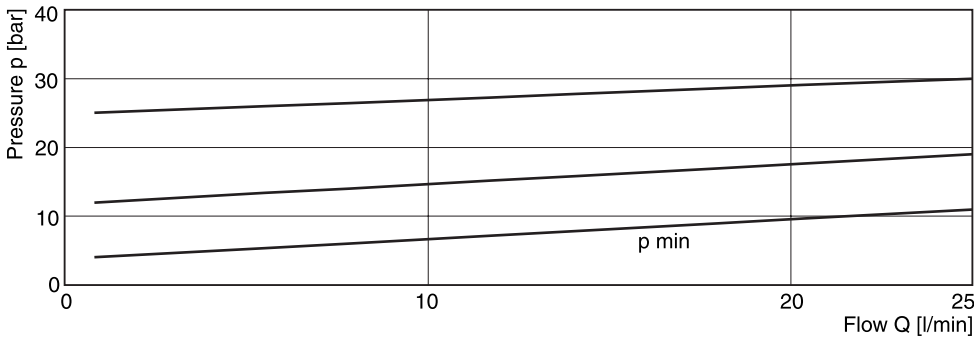

Pressure stage 64 bar

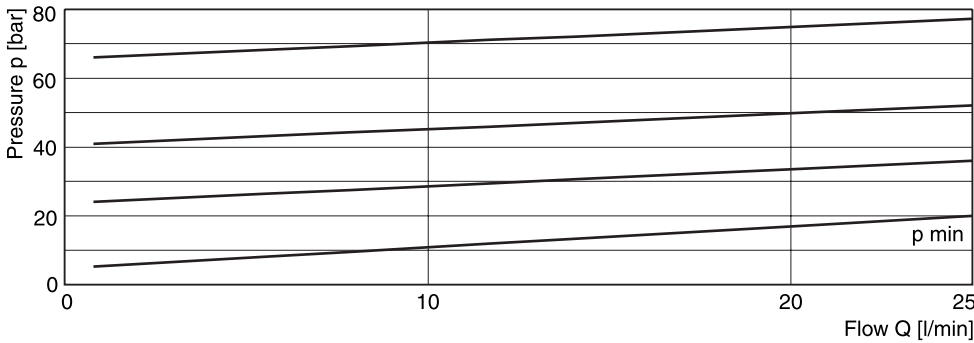

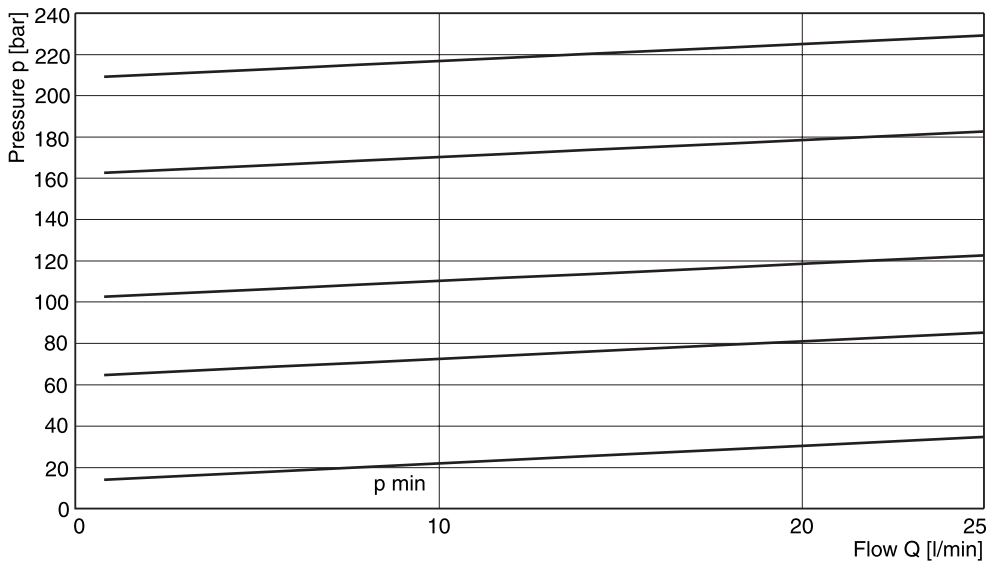

Pressure stage 160, 210 and 350 bar

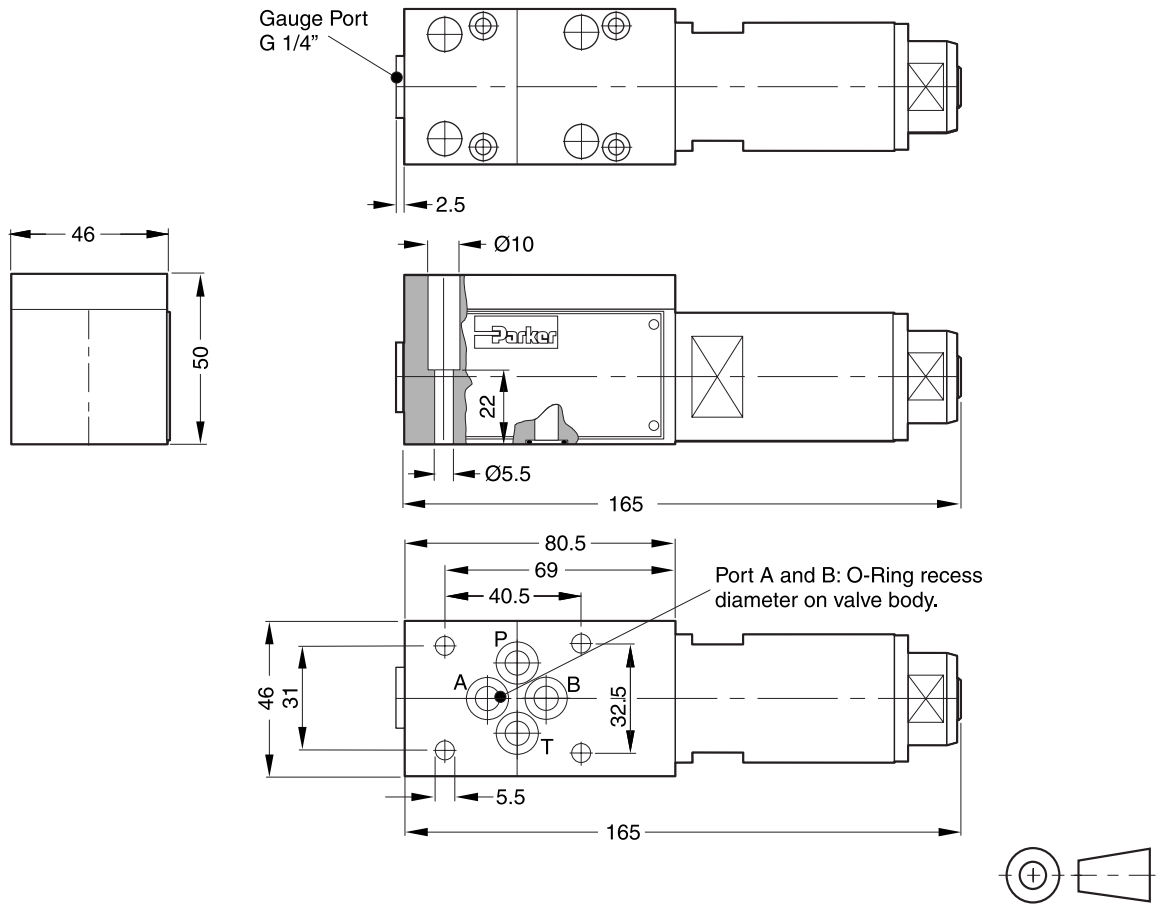

4

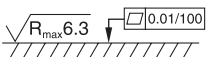

4

Surface finish	Bolt kit  DIN 912 12.9		Kit FPM
	SK-M5x30-4pcs	7.6 Nm ±15%	SK-VB/VM/VS-A06V

Mounting pattern ISO 6264, code 6264-03-04-*-97

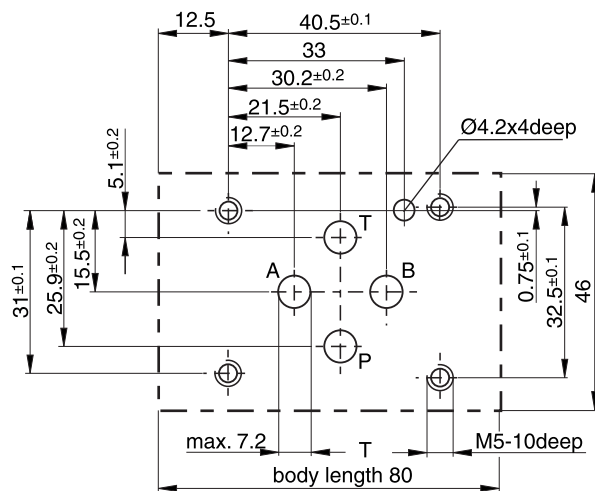

Direct operated pressure relief valve with manual adjustment. The series VB can also be used as a pressure sequence valve, because of the high pressure capability in the outlet port and the external drain port.

Features

- Spool type valve
- Subplate mounting according to ISO 5781
- 5 pressure stages at NG06
- 3 pressure stages at NG10
- 2 adjustment modes



VB*A10

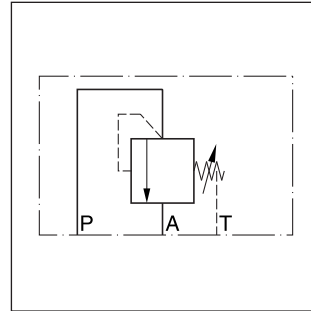

VB*A06

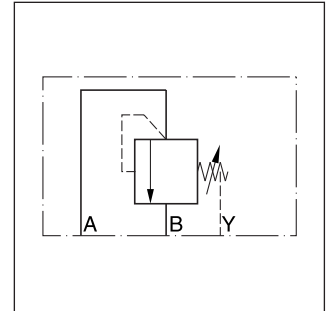

VB*A10

VB*A06

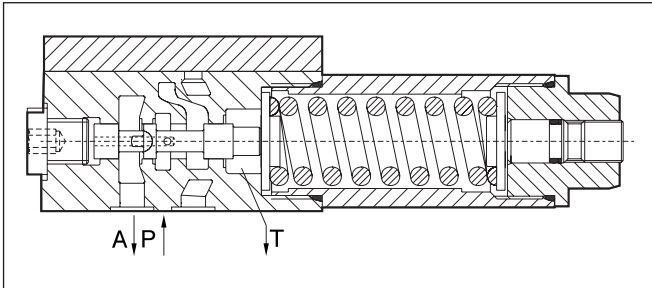

VB*A10

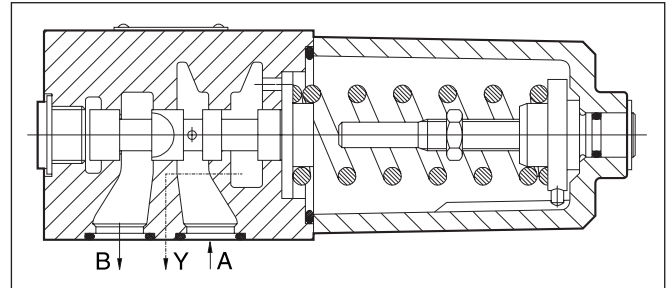

Ordering code

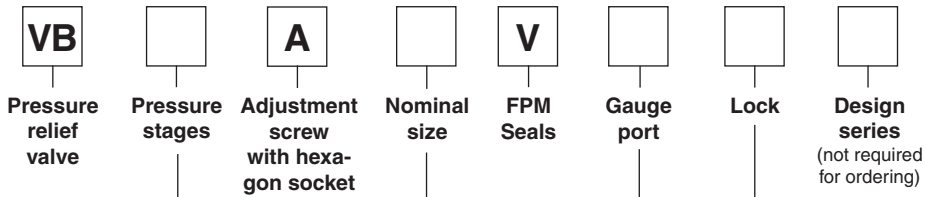

Code	Pressure stages
025 ¹⁾	up to 25 bar
064	up to 64 bar
125 ²⁾	up to 125 bar
160 ¹⁾	up to 160 bar
210	up to 210 bar
350 ¹⁾	up to 350 bar

¹⁾ only NG 06

²⁾ only NG 10

Code	Lock
omit	Normal
Z	DIN lock

Code	Gauge port
G ¹⁾	G 1/4"
M ²⁾	M12x1.5

Code	Nominal size
06	NG 06
10	NG 10

**Bold letters =
Short-term availability**

Technical data

General		Direct operated sequence valve, spool type	
Design			
Nominal size		NG 06 (CETOP 03 / NFPA D03)	NG 10 (CETOP 05 / NFPA D05)
Interface		Subplate mounting according to ISO 5781	
Mounting position		unrestricted	
Ambient temperature	[°C]	-20...+80	
Weight	[kg]	1.3	3.7
Hydraulic			
Max. operating pressure	[bar]	Port P and A 350 Port T depressurized	Port A and B 315 Port Y depressurized
Pressure stages	[bar]	25, 64, 160, 210, 350	64, 125, 210
Nominal flow	[l/min]	25	60
Fluid		Hydraulic oil according to DIN 51524...525	
Fluid temperature	[°C]	-20...+70	
Viscosity recommended	[cSt] / [mm ² /s]	30...50	
permitted	[cSt] / [mm ² /s]	20...380	
Filtration		ISO 4406 (1999) 18/16/13	

4

p/Q performance curves

measured at $t = 50^{\circ}\text{C}$ and $v = 36 \text{ mm}^2/\text{s}$

VB*06

Setting pressure max. 25 bar

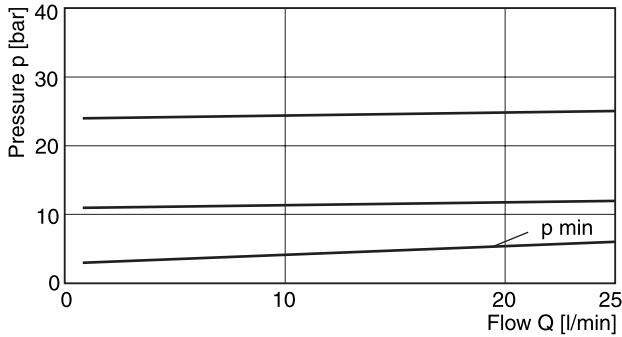

VB*10

Setting pressure max. 64 bar

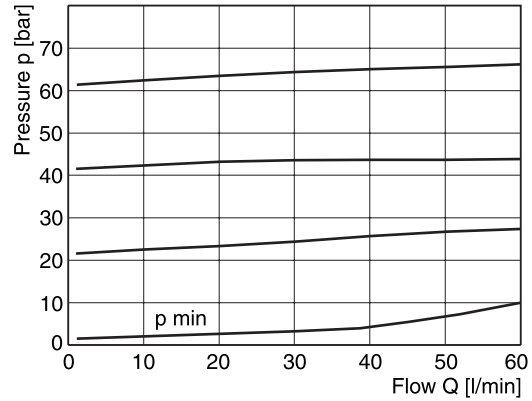

Setting pressure max. 64 bar

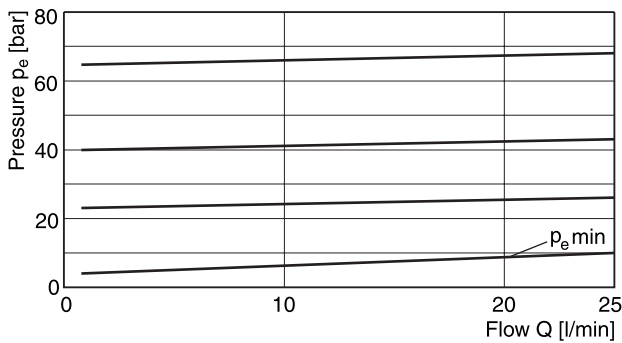

Setting pressure max. 210 bar

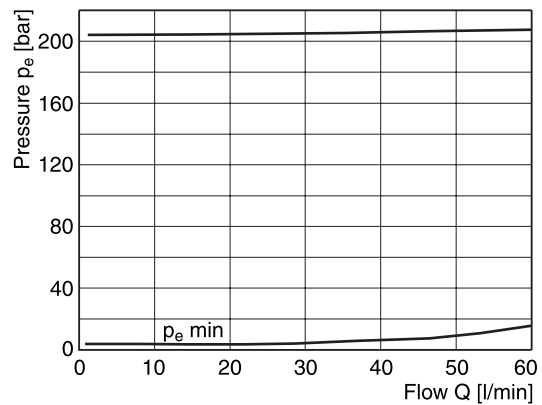

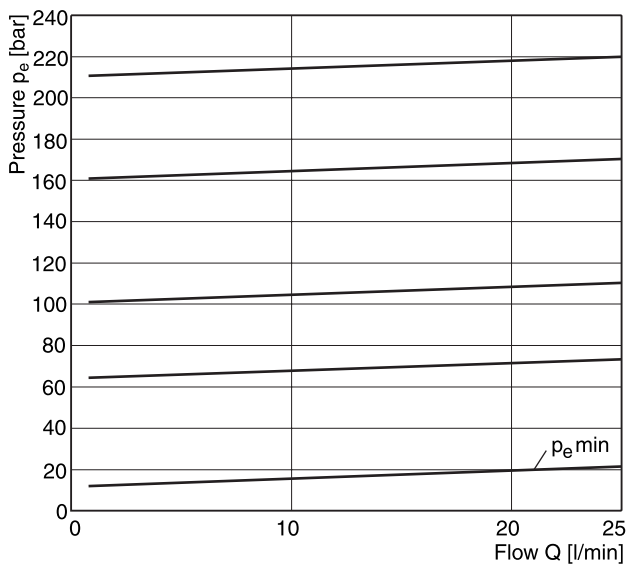

Setting pressure max. 160 or 210 bar

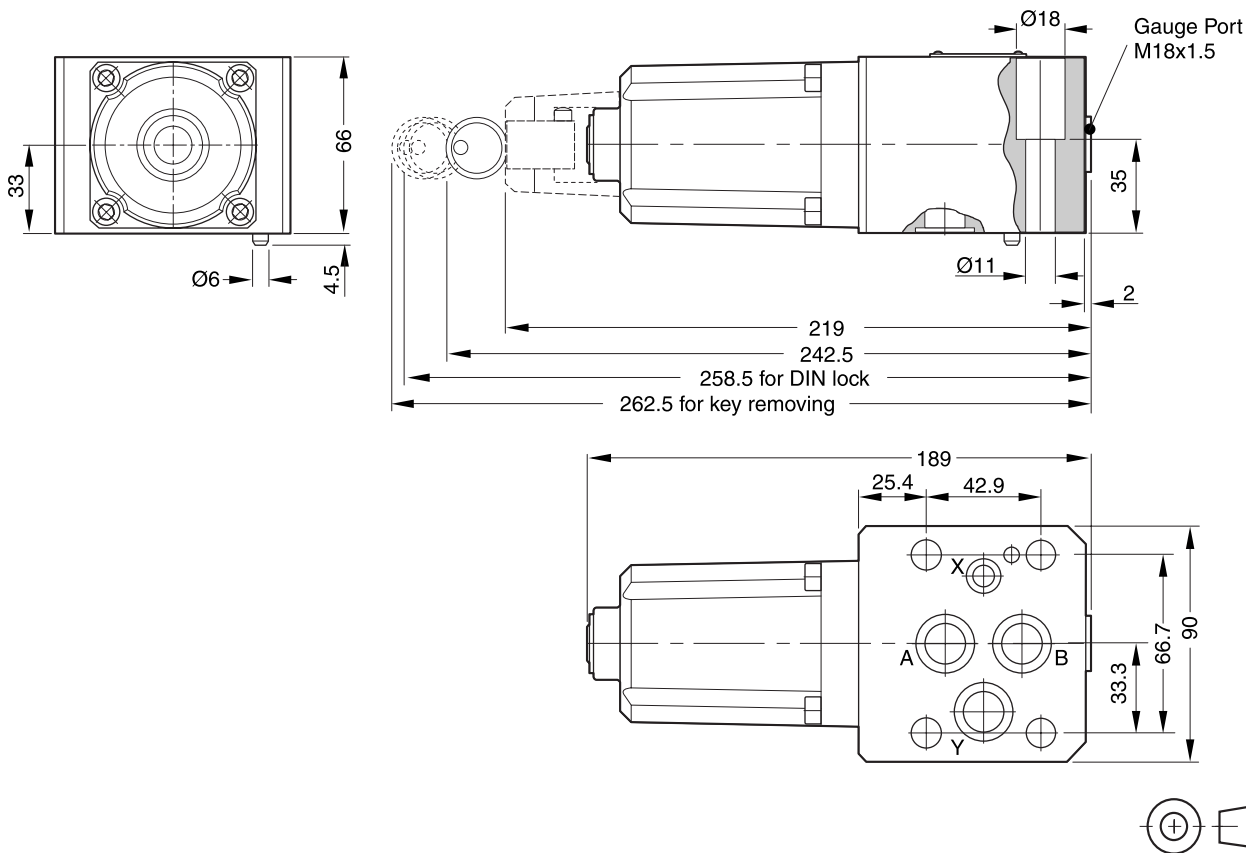

NG10

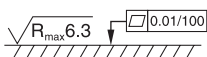

4

Surface finish	Bolt kit  DIN 912 12.9		 Kit FPM
	BK-M10x50-4pcs	63 Nm ±15%	SK-VB/VM-A10V

Mounting pattern ISO 5781-06-07-0-00

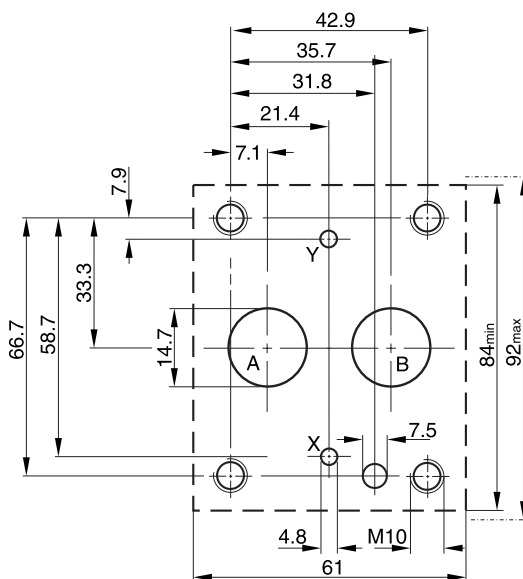

Characteristics

Pilot operated relief valves of the series VBY consist of a pilot with manual adjustment and a spool type main stage. The valves need to be externally drained.

The series VBY can also be used as pressure sequence valve, because of the high pressure capability in the outlet port and the external drain port.

Features

- Subplate mounting acc. to ISO 5781
- Main stage spool type
- Pilot stage seated type
- 4 pressure stages
- 2 adjustment modes
 - screw with hexagon socket
 - DIN lock

Pilot Operated Pressure Relief Valve Series VBY



VBY*A06



VBY*A10

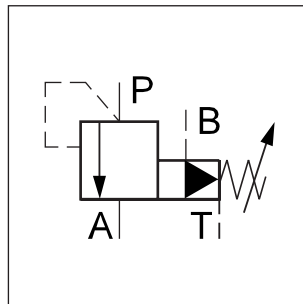

VBY*A06

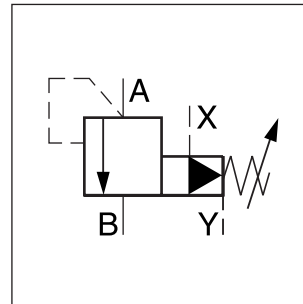

VBY*A10

4

VBY*A06

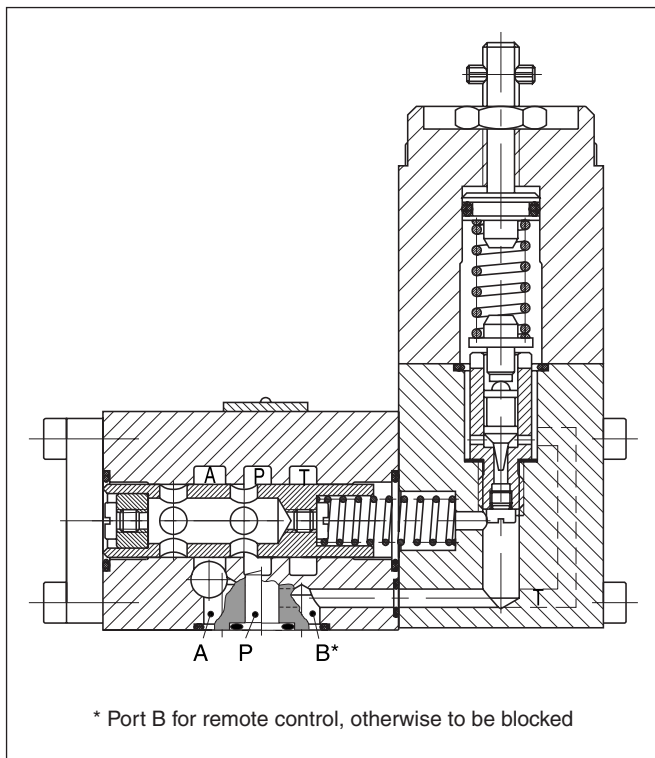

VBY*A10

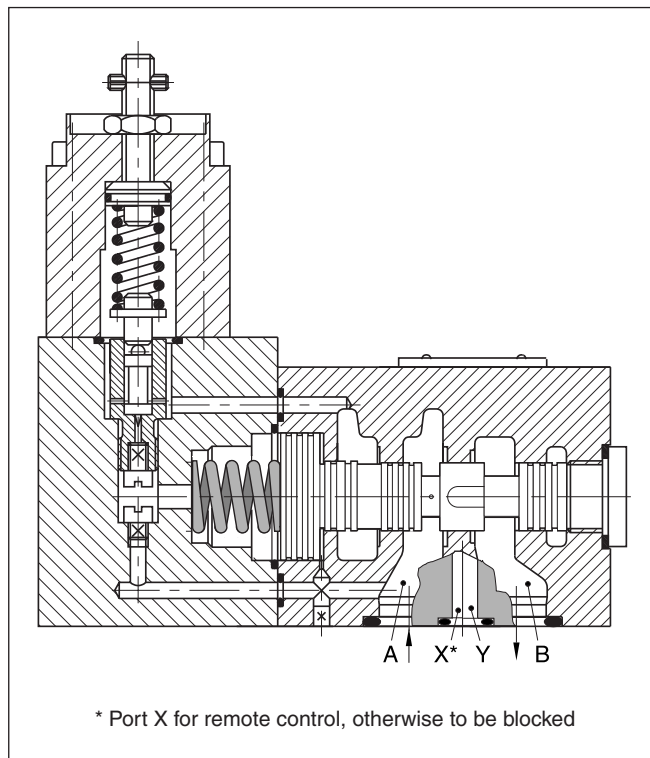

Ordering Code / Technical Data

Ordering code

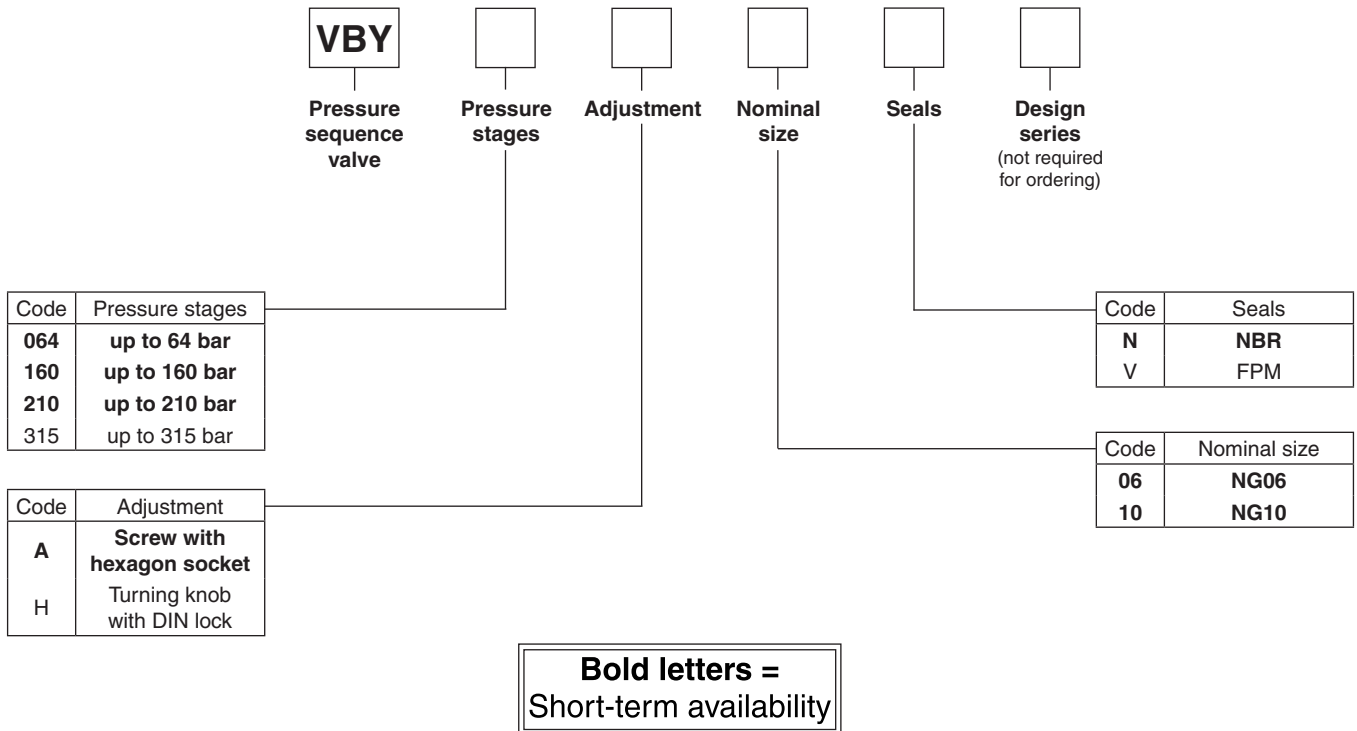

Technical data

Nominal size	NG06		NG10	
	Design	Pilo operated sequence valve, spool type		
Interface	Subplate mounting according to ISO 5781			
Mounting position	unrestricted			
Ambient temperature	[°C]	-20...+80		
Max. operating pressure	[bar]	P, A, B 315	A, B, X 315	
External drain port pressure	[bar]	T 100	Y 100	
Pressure stages	[bar]	64, 160, 210, 315		
Fluid temperature	[°C]	-20...+70		
Viscosity, recommended	[cSt] / [mm²/s]	30...50		
permitted	[cSt] / [mm²/s]	20...380		
Filtration		ISO 4406 (1999) 18/16/13		
Nominal flow	[l/min]	See p/Q curves		
Pilot oil flow	[cm³/min]	approx. 500	approx. 1000	
Weight	[kg]	2.4	4.5	

p/Q performance curves VBY
 measured at $t = 50^{\circ}\text{C}$ and $v = 36 \text{ mm}^2/\text{s}$
NG06

Max. 64 bar NG06

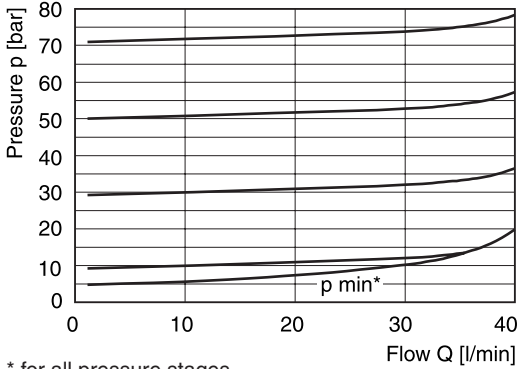

* for all pressure stages

Max. 160 bar NG06

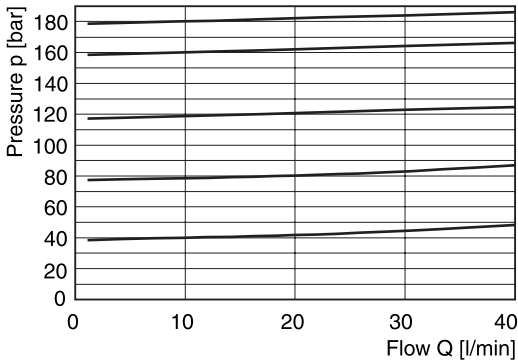

Max. 210 bar NG06

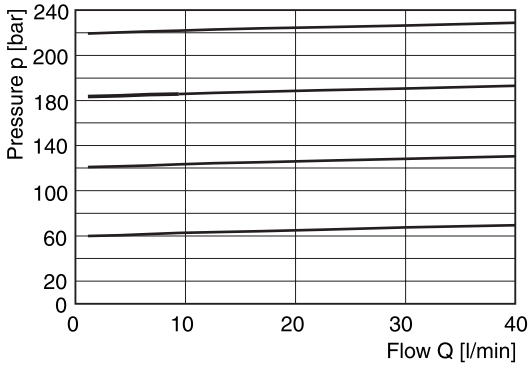

Max. 315 bar NG06

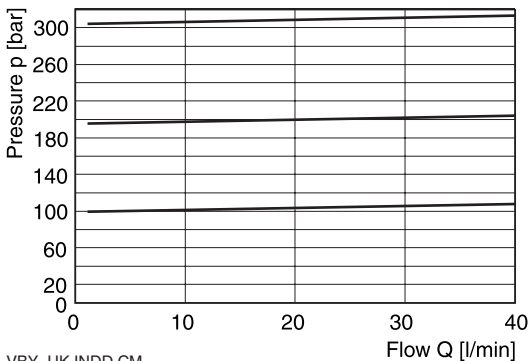

NG10

Max. 64 bar NG10

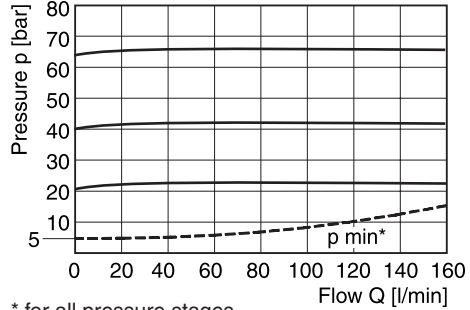

* for all pressure stages

Max. 160 bar NG10

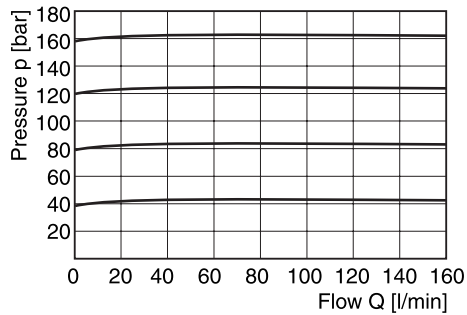

Max. 210 bar NG10

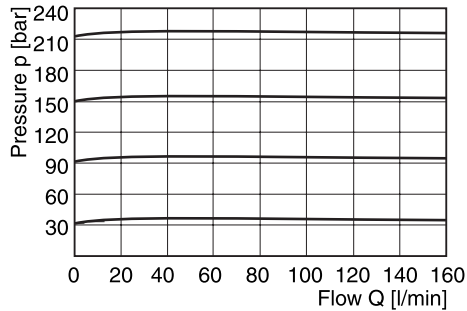

Max. 315 bar NG10

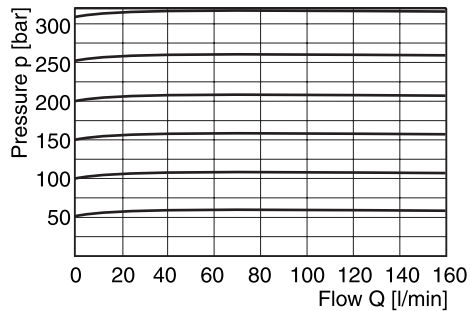

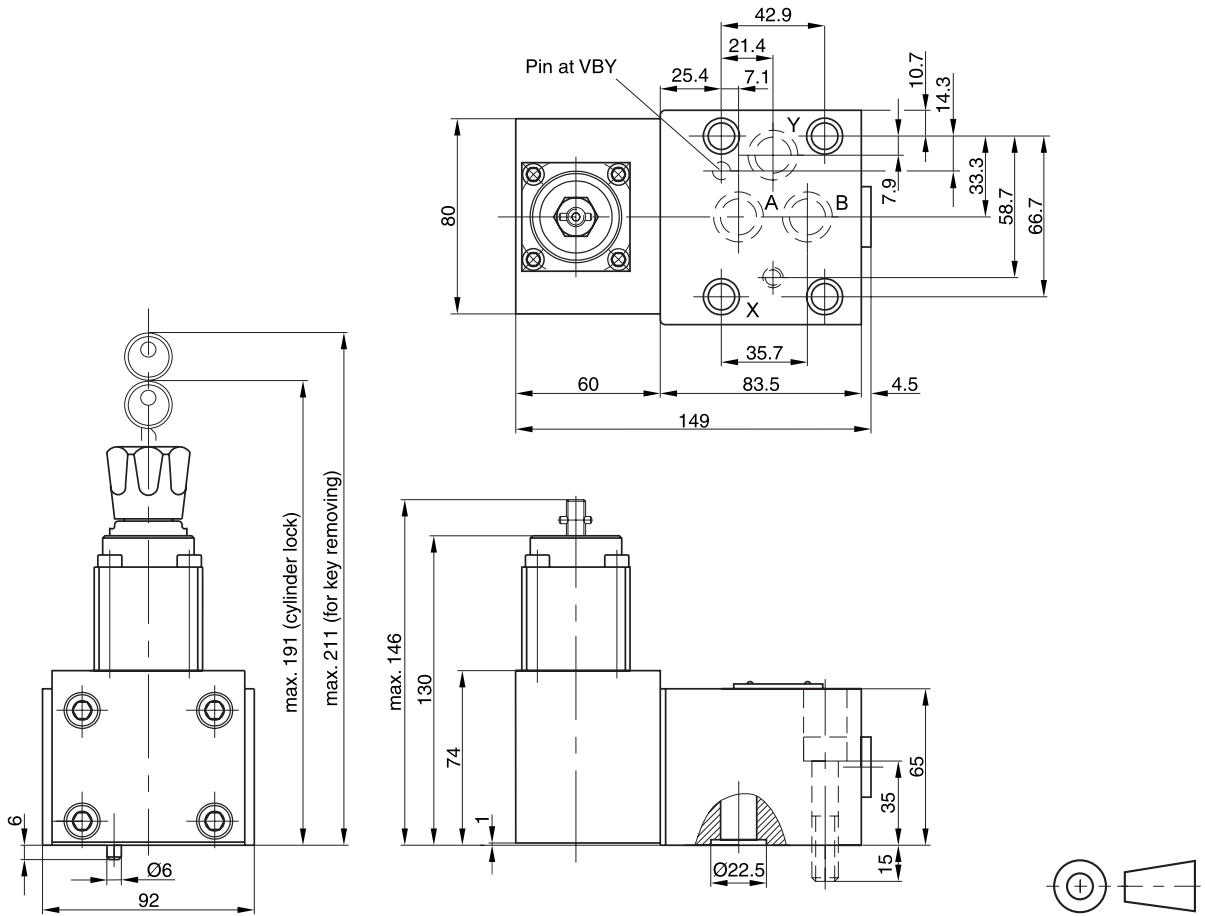

VBY_UK.INDD.CM

NG10

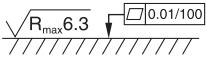

4

Surface finish	Bolt kit  DIN 912 12.9		 Kit FPM
	BK-M10x50-4pcs	63 Nm ±15%	SK-VB/VM-A10V

Mounting pattern ISO 5781-06-07-0-00

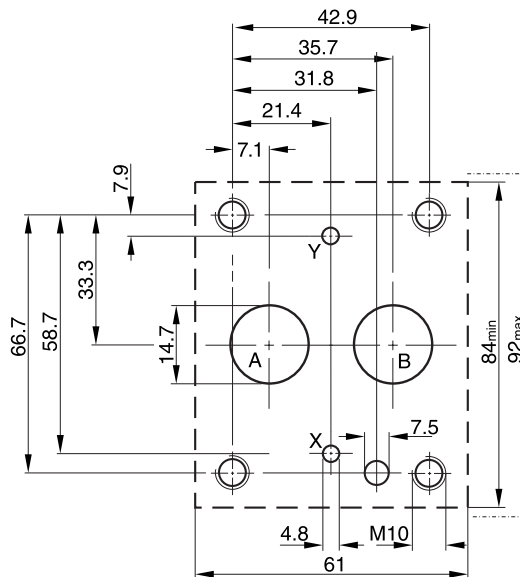

VBY_UK.INDD CM

The direct operated pressure relief valve series EVSA is a seated type valve for screw-in mounting. It is available in two sizes and three pressure stages.

Function

When the pressure in port P exceeds the setting pressure the cone opens to port T and thus limits the pressure in port P to the adjusted level.

The integrated damping spool prevents pressure fluctuations in the transition region. The pressure is set by the adjusting screw, which is locked by the clamping screw. The setting can optionally be secured by a cylinder lock (DIN lock).

Features

- Seated type valve
- Screw-in mounting
- 3 pressure stages
- 2 adjustment modes
 - screw with lock nut
 - DIN lock

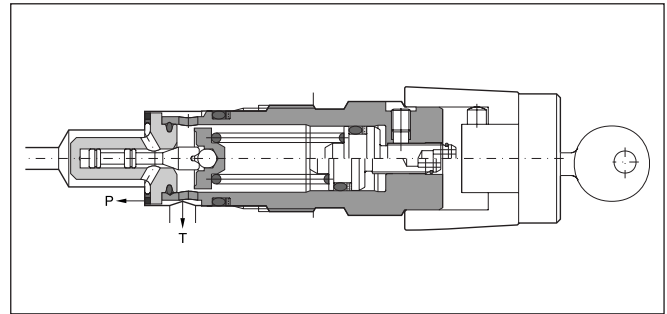
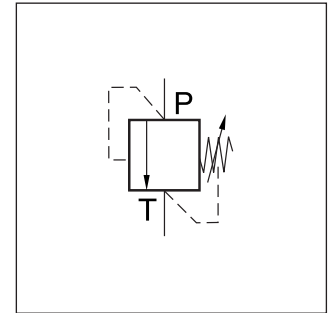

Note

The spring must be unloaded when the EVSA is screwed out of the manifold.

Technical data

General		Direct operated relief valve, seated type	
Design		Direct operated relief valve, seated type	
Nominal size		NG06	NG10
Interface		Screw-in mounting	
Mounting position		unrestricted	
Ambient temperature	[°C]	-20...+80	
Weight	[kg]	0.3	0.45
Hydraulics			
Max. operating pressure	[bar]	Port P 350, Port T depressurized	
Pressure stages	[bar]	64, 160, 350	
Nominal flow	[l/min]	40 (NG06), 80 (NG10)	
Fluid		Hydraulic oil according to DIN 51524...525	
Fluid temperature	[°C]	Recommended +30...+50, permitted -20...+70	
Viscosity permitted	[cSt] / [mm²/s]	20...380	
recommended	[cSt] / [mm²/s]	30...50	
Filtration		ISO 4406 (1999); 18/16/13	

Ordering code

EVSA		A		1																
Pressure relief valve	Pressure stages	Adjustment screw with hex. socket	Nominal size / thread type	FPM Seals	Design series <small>(not required for ordering)</small>	Lock														
	<table border="1" style="width: 100%; border-collapse: collapse;"> <tr> <th>Code</th> <th>Pressure stages</th> </tr> <tr> <td>064</td> <td>up to 64 bar</td> </tr> <tr> <td>160</td> <td>up to 160 bar</td> </tr> <tr> <td>350</td> <td>up to 350 bar</td> </tr> </table>	Code	Pressure stages	064	up to 64 bar	160	up to 160 bar	350	up to 350 bar					<table border="1" style="width: 100%; border-collapse: collapse;"> <tr> <th>Code</th> <th>Lock</th> </tr> <tr> <td>omit</td> <td>Normal</td> </tr> <tr> <td>Z</td> <td>DIN lock</td> </tr> </table>	Code	Lock	omit	Normal	Z	DIN lock
Code	Pressure stages																			
064	up to 64 bar																			
160	up to 160 bar																			
350	up to 350 bar																			
Code	Lock																			
omit	Normal																			
Z	DIN lock																			
		Bold letters = Short-term availability				<table border="1" style="width: 100%; border-collapse: collapse;"> <tr> <th>Code</th> <th>Nominal size</th> </tr> <tr> <td>06</td> <td>NG06, M28x1.5</td> </tr> <tr> <td>10</td> <td>NG10, M35x1.5</td> </tr> </table>	Code	Nominal size	06	NG06, M28x1.5	10	NG10, M35x1.5								
Code	Nominal size																			
06	NG06, M28x1.5																			
10	NG10, M35x1.5																			

EVSA_UK.INDD CM



$\Delta p/Q$ performance curves
 measured at $t = 50^\circ\text{C}$ and $v = 36 \text{ mm}^2/\text{s}$

NG06

Pressure stage 64 bar

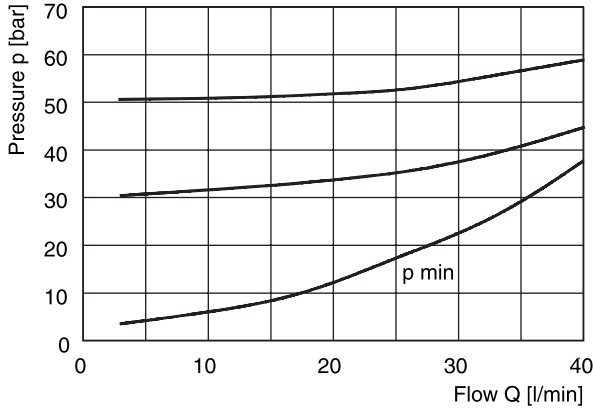

NG10

Pressure stage 64 bar

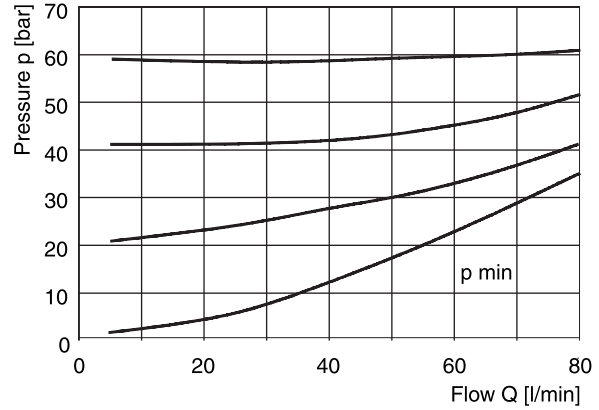

Pressure stage 160 bar

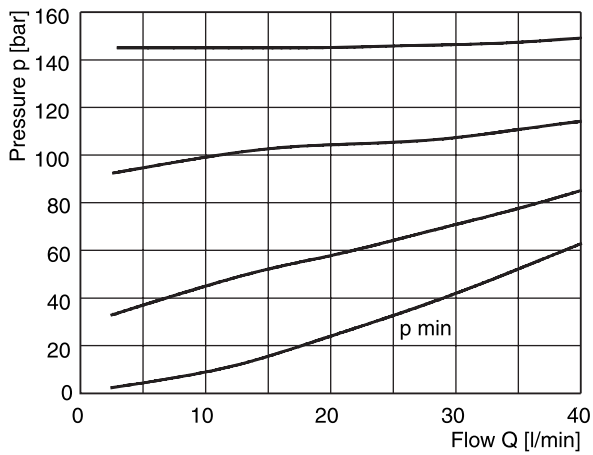

Pressure stage 160 bar

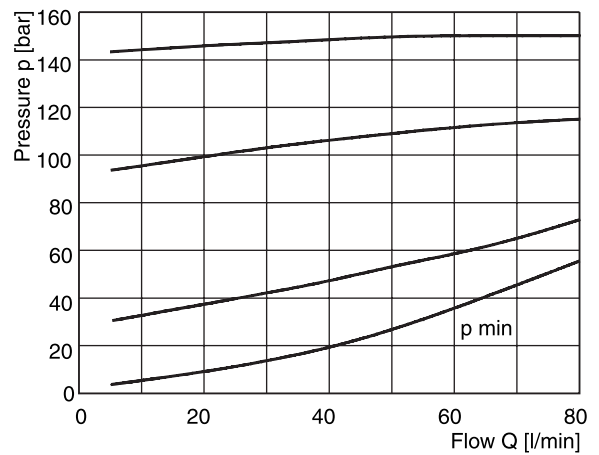

Pressure stage 350 bar

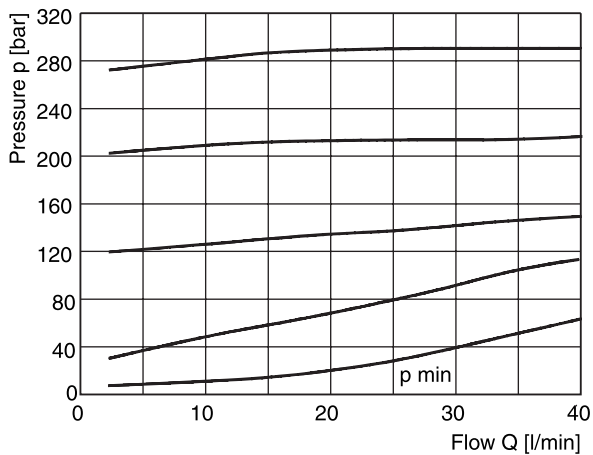

Pressure stage 350 bar

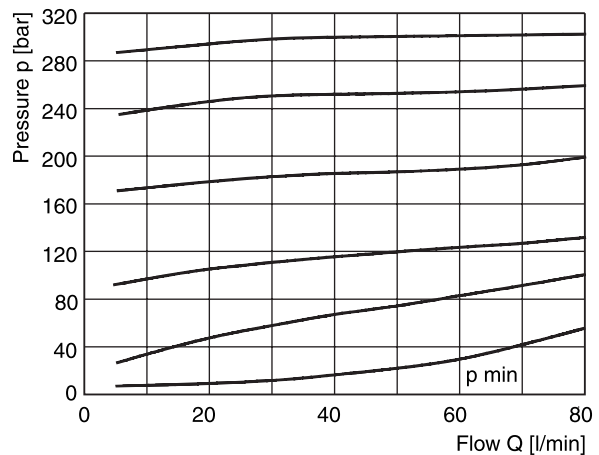

4

EVSA NG06

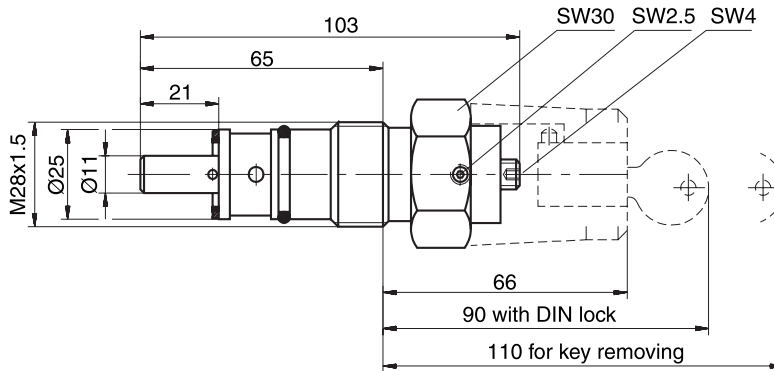

○ Kit
SK-EVSA0613

EVSA NG10

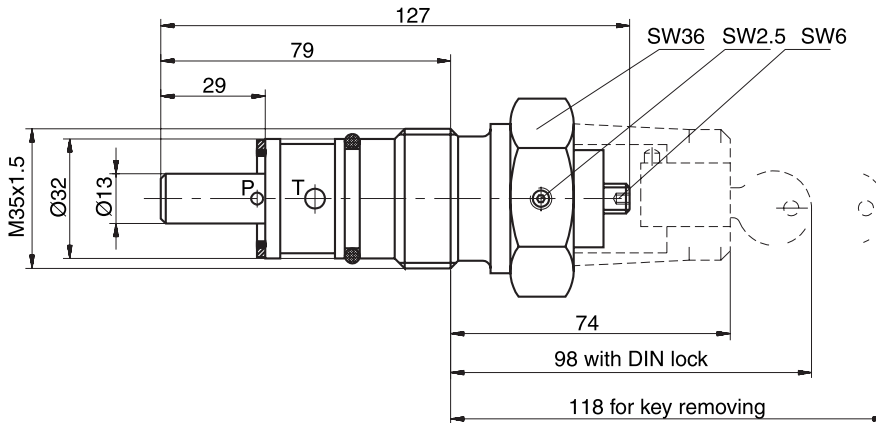

○ Kit
SK-EVSA01013

Installation dimensions

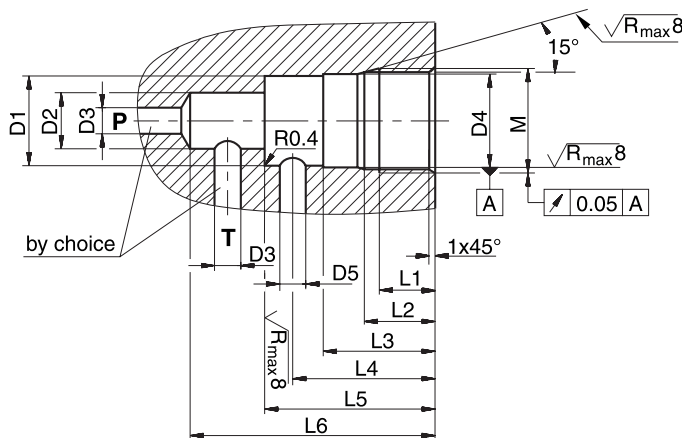

Size	M	D ₁	D ₂	D ₃	D ₄	D ₅	L ₁	L ₂	L ₃	L ₄	L ₅	L ₆
NG06	M28 x 1.5	Ø24.8	Ø15	Ø6.8	Ø25 ^{H9}	Ø6.8	15	19	30	35	45	65
NG10	M35 x 1.5	Ø31.8	Ø18.5	Ø10	Ø32 ^{H9}	Ø10	18	23	35	41 - 46	52	80

Characteristics

Pilot operated pressure relief valves are available with both Parker (series R/RS) and Denison (series R4V/R6V) model codes.

A manually adjusted pilot stage controls a seated type main stage.

A vent function with a solenoid operated directional valve is available for circulation at minimum pressure.

Features

- Pilot operated with manual adjustment
- 2 interfaces
 - Subplate ISO 6264 (DIN 24340 Form D) with VV01 vent valve
 - Subplate ISO 6264 (DIN 24340 Form E) with Cetop 03 vent valve
- 4 pressure stages
- 3 adjustment modes
 - hand knob
 - acorn nut with lead seal
 - DIN lock
- Remote control via port X

**Pilot Operated Pressure Relief Valves
Series R / RS (Parker), R*V (Denison)**



R25R



RS25R

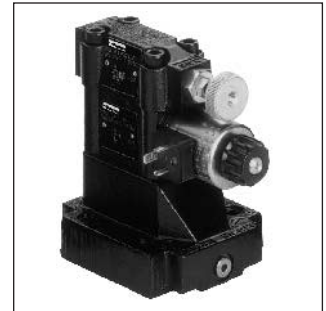
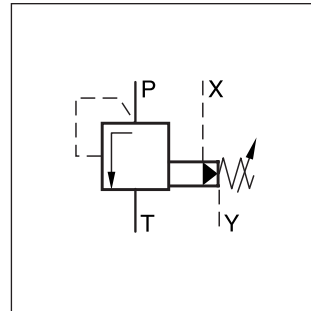

RS25M

RS25R

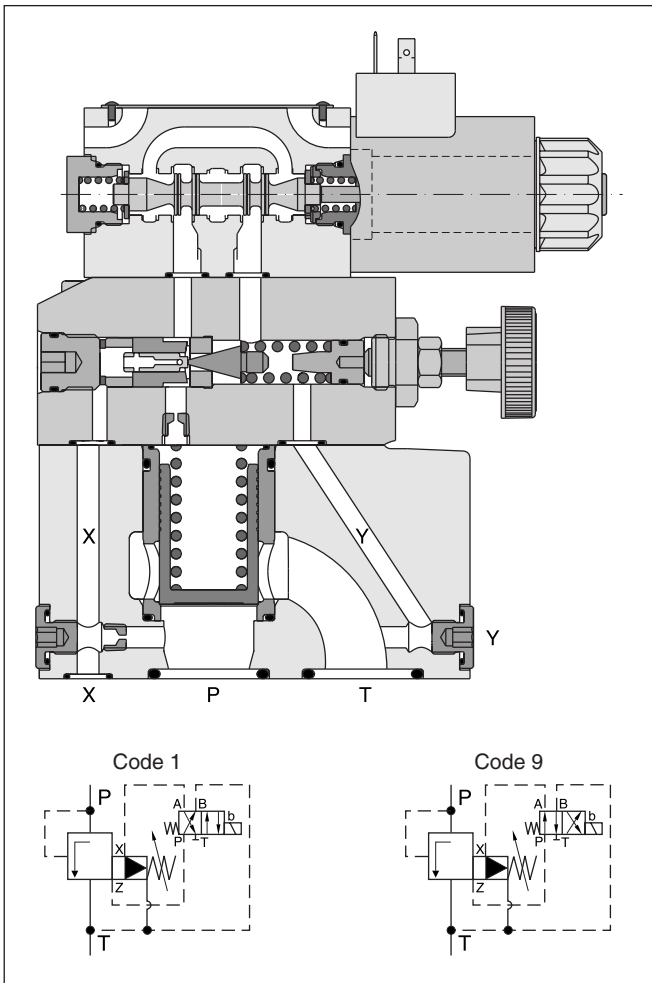

Function:

Series R

System pressure in port P is applied via the X gallery to the spring loaded cone in the pilot head. The pilot head controls the pressure in the Z area on top of the main cartridge which is additionally kept close by the main spring.

If the pilot pressure exceeds the setting pressure the pilot cone opens and thus limits the pilot pressure.

When the system pressure exceeds the pilot pressure plus the spring force, the main cartridge opens to port T and limits the pressure in port P to the adjusted level.

Series RS

Additionally to the relief function of series R, a solenoid operated vent valve connects the Z area to tank. This allows oil circulation from P to T at minimum pressure drop. The vent valve can either be a standard Cetop 03 valves (mounting form E) or a sandwich unit (mounting form D). For both types the vent position can be either at the energized or de-energized solenoid.

R-RS-R4V-R6V_UK.INDD CM



4

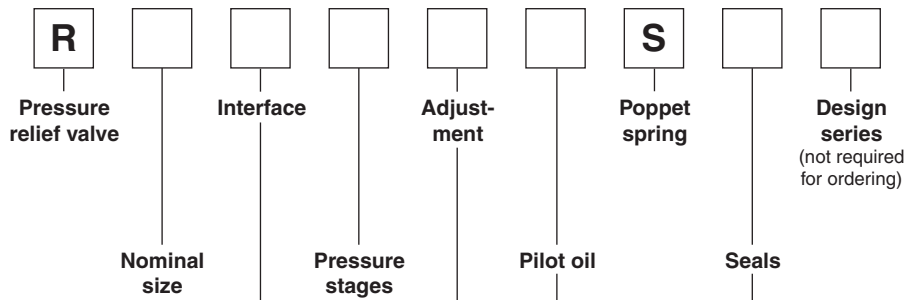

Code	Nominal size
10	NG10
25	NG25
32	NG32

Code	Seals
N	NBR
V	FPM

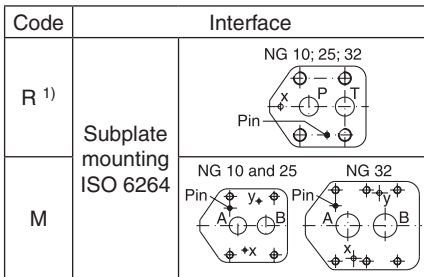

¹⁾ drain line with pipe only

Code	Pressure stages
07	up to 70 bar
17	up to 175 bar
25	up to 250 bar
35	up to 350 bar

Pilot oil		
Code	Pilot	Drain
1	Internal	External
4	Internal	Internal

Code	Adjustment
S	Hand knob (Standard)
L	DIN lock
A	Acorn nut with lead seal



The Parker model code should be used for all new applications. Otherwise also refer to Denison model code.

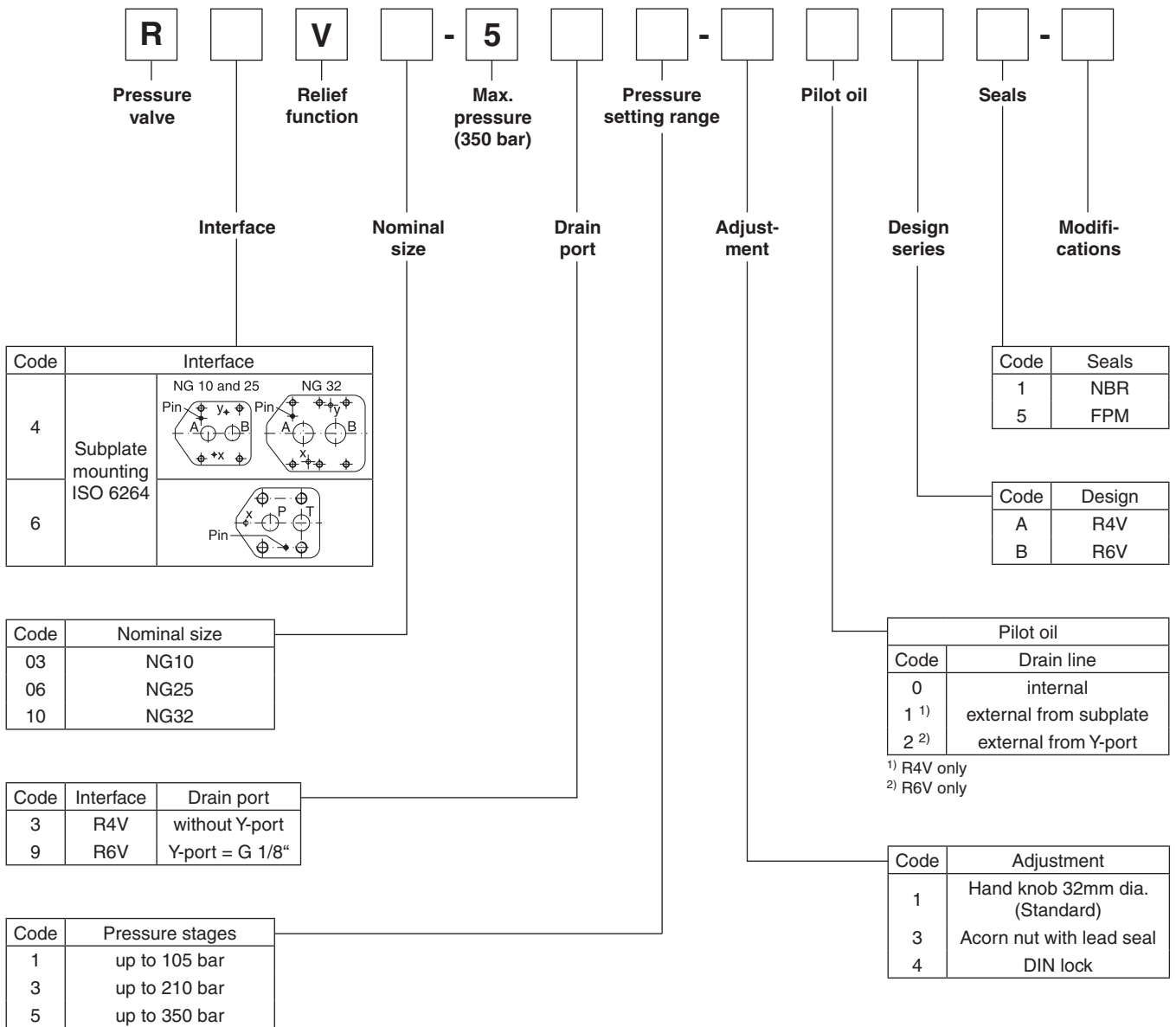

4

DENISON Hydraulics

The Denison model code is available for existing applications. Otherwise also refer to Parker model code.

4

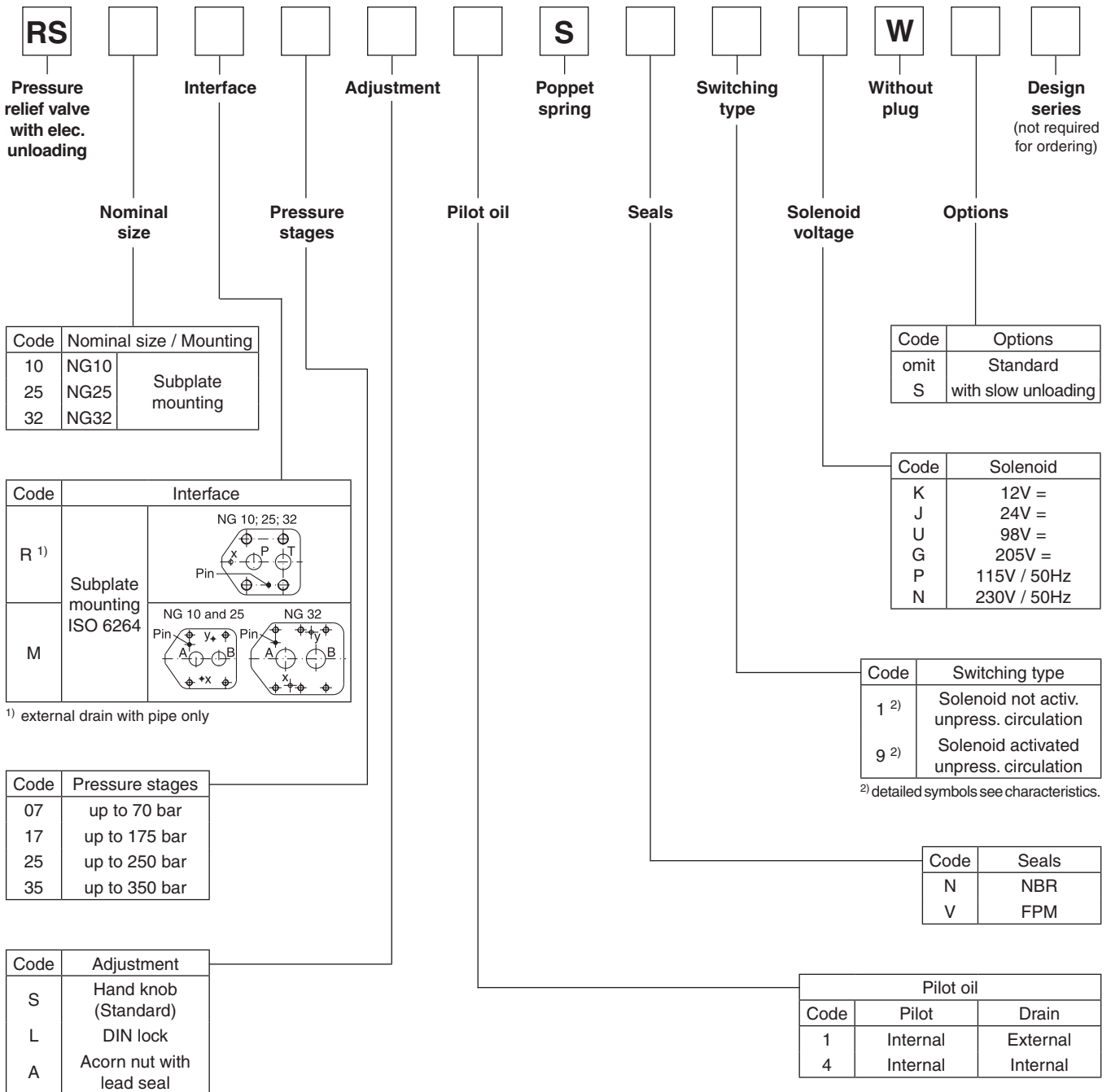

Other solenoid voltages on request.

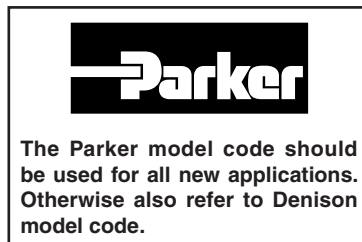

Ordering Code

**Pilot Operated Pressure Relief Valves
R*V with Vent Function (Denison)**

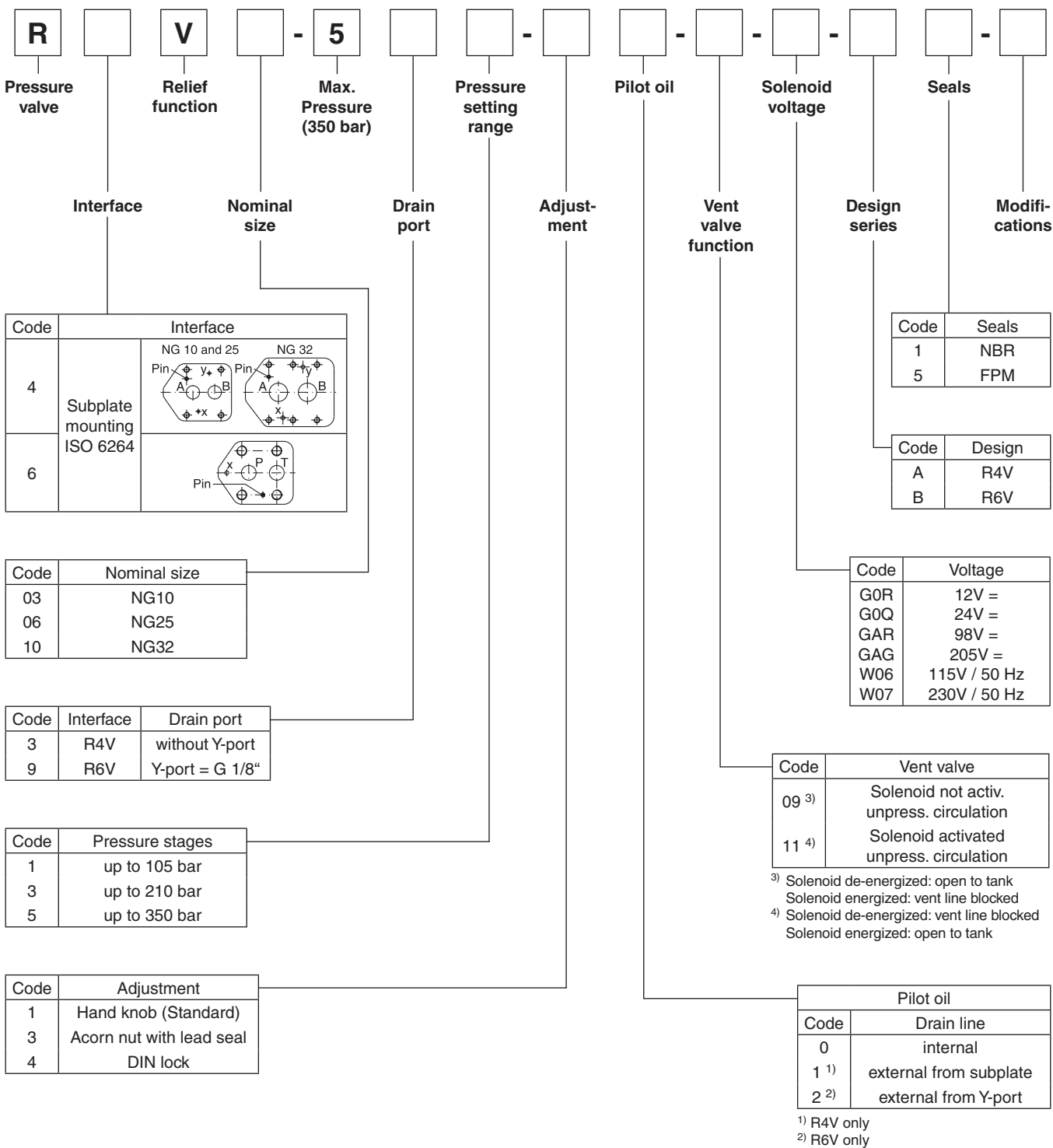

4

DENISON Hydraulics

The Denison model code is available for existing applications. Otherwise also refer to Parker model code.

R / R*V

General			10	25	32
Nominal size					
Interface		Subplate mounting acc. ISO 6264			
Mounting position		as desired, horizontal mounting preferred			
Ambient temperature	[°C]	-20...+80			
Weight	Series R*R / R6V	[kg]	4.5	5.8	7.8
	Series R*M / R4V	[kg]	2.7	4.5	6.0
Hydraulic					
Max. operating pressure	[bar]	Ports P (or A) and X up to 350, Port T (or B) and Y depressurized			
Pressure stages	[bar]	75, 175, 250, 350 (series R) : 105, 210, 350 (series R*V)			
Nominal flow	Series R*R / R6V	[l/min]	250	500	650
	Series R*M / R4V	[l/min]	150	350	650
Fluid		Hydraulic oil according to DIN 51524 ... 525			
Viscosity, recommended	[cSt] / [mm²/s]	30 ... 50			
	permitted	[cSt] / [mm²/s]	20 ... 380		
Fluid temperature	[°C]	-20 ... +70			
Filtration		ISO 4406 - (1999) ; 18/16/13			

4

RS / R*V with vent function

General			10	25	32		
Nominal size							
Interface		Subplate mounting acc. ISO 6264					
Mounting position		as desired, horizontal mounting preferred					
Ambient temperature	[°C]	-20...+80					
Weight	Series RS*R / R6V	[kg]	5.9	7.2	9.2		
	Series RS*M / R4V	[kg]	4.4	6.2	7.7		
Hydraulic							
Max. operating pressure	[bar]	Ports P (or A) and X 350, port T (or B) and Y depressurized					
Pressure stages	[bar]	75, 175, 250, 350 (series R) : 105, 210, 350 (series R*V)					
Nominal flow	Series RS*R / R6V	[l/min]	250	500	650		
	Series RS*M / R4V	[l/min]	150	350	650		
Fluid		Hydraulic oil according to DIN 51524 ... 525					
Viscosity, recommended	[cSt] / [mm²/s]	30 ... 50					
	permitted	[cSt] / [mm²/s]	20 ... 380				
Fluid temperature	[°C]	-20 ... +70					
Filtration		ISO 4406 - (1999) ; 18/16/13					
Electrical							
Duty ratio	[%]	100 ED; CAUTION: coil temperature up to 180 °C possible					
Max. switching frequency	[1/h]	16000 (DC), 7200 (AC)					
Protection class		IP 65 in according with EN 60529 (plugged and mounted)					
Code Denison / Code Parker		G0R / K	G0Q / J	GAR / U	GAG / G	W06 / P	W07 / N
Supply voltage	[V]	12V =	24V =	98V =	205V =	150 at 50Hz	230 at 50Hz
Tolerance supply voltage	[%]	+5...-10	+5...-10	+5...-10	+5...-10	+5...-10	+5...-10
Power consumption	hold	[W]	31	31	31	78	78
	in rush	[W]	31	31	31	264	264
Solenoid connection		Connector as per EN 175301-803					
Wiring min.	[mm²]	3 x 1.5 recommended					
Wiring length max.	[m]	50 recommended					

p/Q performance curve

Series R/RS*M / R4V ¹⁾

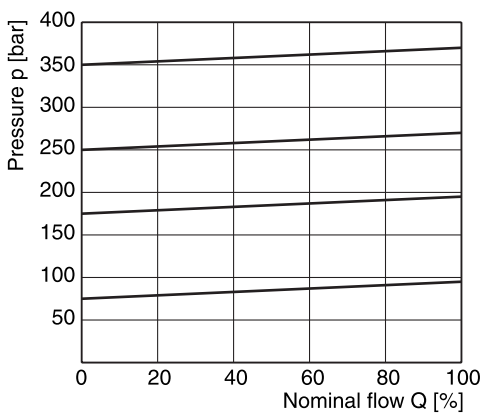

Minimum pressure curve

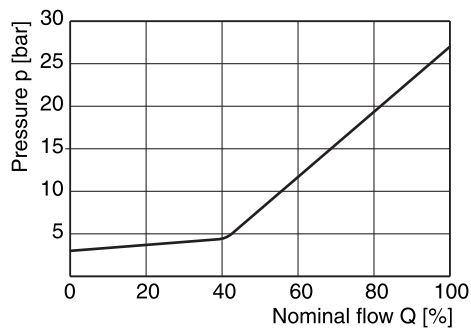

p/Q performance curve

Series R/RS*R/R6V ¹⁾

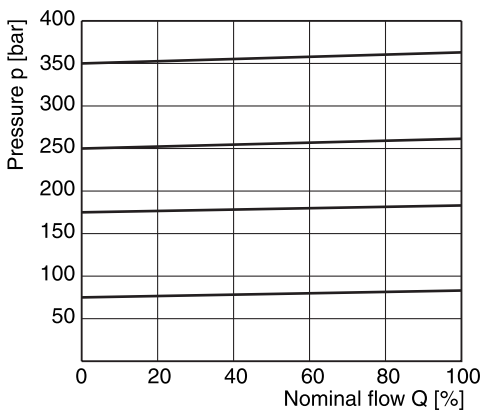

Minimum pressure curve

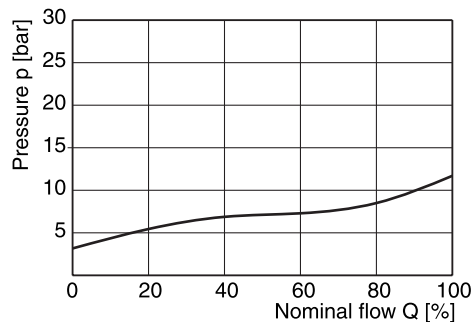

1) The performance curves are measured with external drain.
 For internal drain the tank pressure has to be added to curve.

R*R / R6V

4

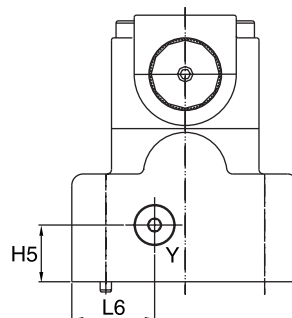
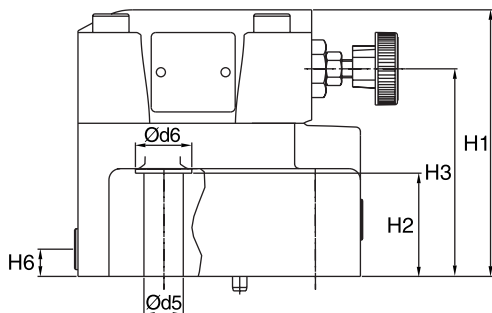
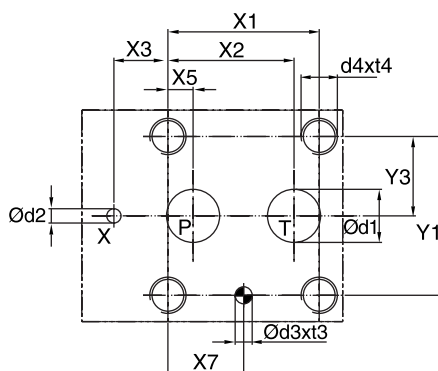
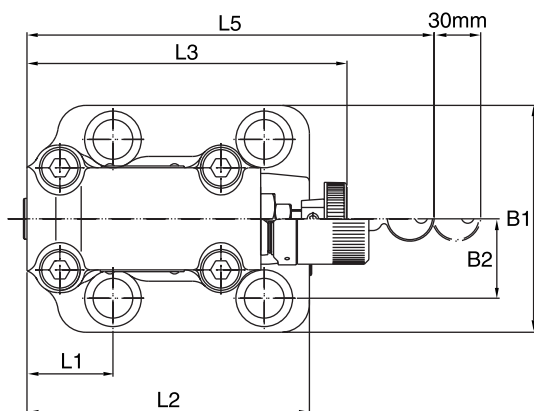

Y: external drain port G 1/8"



NG	ISO-code	x1	x2	x3	x4	x5	x6	x7	y1	y2	y3	y4	y5	y6
10	6264-06-09-*97	53.8	47.5	0	-	22.1	-	22.1	53.8	-	26.9	-	-	-
25	6264-08-13-*97	66.7	55.6	23.8	-	11.1	-	33.4	70	-	35	-	-	-
32	6264-10-17-*97	88.9	76.2	31.8	-	12.7	-	44.5	82.6	-	41.3	-	-	-

Tolerance at X and Y pin holes and screw holes ±0.1, at port holes ±0.2.

NG	ISO-code	B1	B2	H1	H2	H3	H4	H5	H6	L1	L2	L3	L4	L5	L6
10	6264-06-09-*97	80	26.9	114	27	88	-	20.5	25	52.5	118.5	141	-	180	29.5
25	6264-08-13-*97	100	35	117.5	45.5	91.5	-	25	12	37.9	124.5	141	-	180	36.5
32	6264-10-17-*97	120	41.3	123	52	97	-	26.5	13.5	45	153	141	-	180	46.5

NG	ISO-code	d1max	d2max	d3	t3	d4	t4	d5	d6
10	6264-06-09-*97	14.7	4.8	7.5	10	M12	20	13.5	20
25	6264-08-13-*97	23.4	6.3	7.5	10	M16	27	17.5	25
32	6264-10-17-*97	32	6.3	7.5	10	M18	28	20	30

NG	ISO-code	Bolt kit - DIN912 12.9		Kit		Surface finish
				NBR	FPM	
10	6264-06-09-*97	BK-M12 x 45-4pcs	108 Nm ±15%	SK-R10RN50	SK-R10RV50	$\sqrt{R_{max} 6.3}$
25	6264-08-13-*97	BK-M16 x 70-4pcs	264 Nm ±15%	SK-R25RN50	SK-R25RV50	
32	6264-10-17-*97	BK-M18 x 75-4pcs	398 Nm ±15%	SK-R32RN50	SK-R32RV50	

R-RS-R4V-R6V_UK.INDD CM



RS*R / R6V with vent function

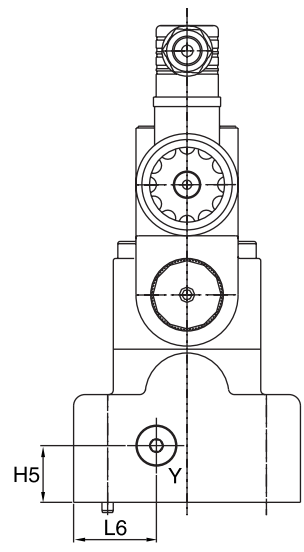
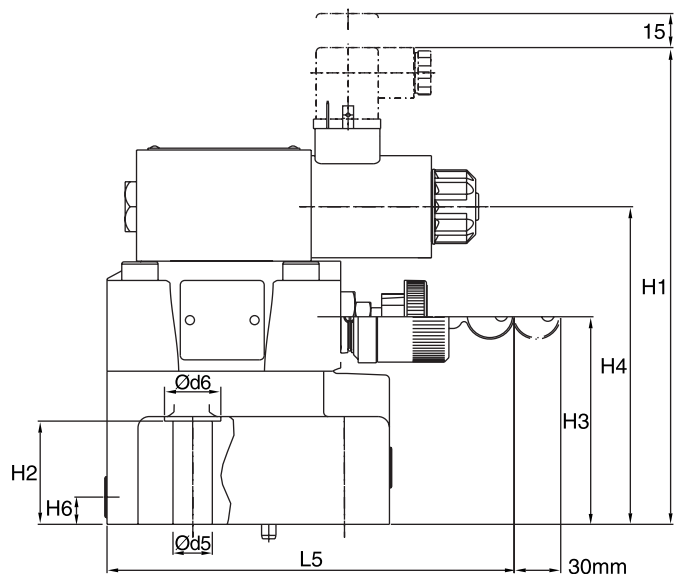
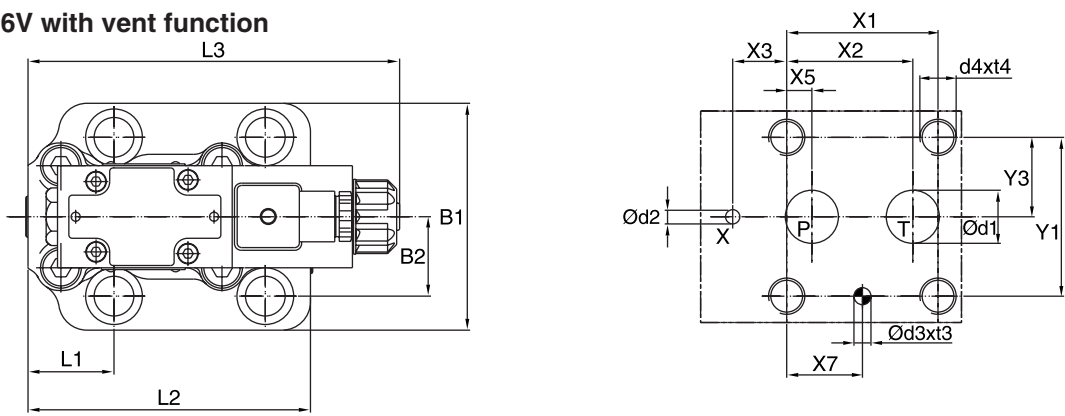

Y: external drain port G 1/8"



NG	ISO-code	x1	x2	x3	x4	x5	x6	x7	y1	y2	y3	y4	y5	y6
10	6264-06-09-*-97	53.8	47.5	0	-	22.1	-	22.1	53.8	-	26.9	-	-	-
25	6264-08-13-*-97	66.7	55.6	23.8	-	11.1	-	33.4	70	-	35	-	-	-
32	6264-10-17-*-97	88.9	76.2	31.8	-	12.7	-	44.5	82.6	-	41.3	-	-	-

Tolerance at X and Y pin holes and screw holes ±0.1, at port holes ±0.2.

NG	ISO-code	B1	B2	H1	H2	H3	H4	H5	H6	L1	L2	L3	L4	L5	L6
10	6264-06-09-*-97	80	26.9	206	27	88	136.5	25	12	52.5	118.5	163.8	-	180	36.5
25	6264-08-13-*-97	100	35	210	45.5	91.5	140	25	12	37.9	124.5	163.8	-	180	36.5
32	6264-10-17-*-97	120	41.3	215.5	52	97	145.5	25	12	45	153	163.8	-	180	36.5

NG	ISO-code	d1max	d2max	d3	t3	d4	t4	d5	d6
10	6264-06-09-*-97	14.7	4.8	7.5	10	M12	20	13.5	20
25	6264-08-13-*-97	23.4	6.3	7.5	10	M16	27	17.5	25
32	6264-10-17-*-97	32	6.3	7.5	10	M18	28	20	30

NG	ISO-code	Bolt kit - DIN912 12.9		Kit		Surface finish
				NBR	FPM	
10	6264-06-09-*-97	BK-M12 x 45-4pcs	108 Nm ±15%	SK-RS10RN50	SK-RS10RV50	$\sqrt{R_{max} 6.3}$ $\square 0.01/100$
25	6264-08-13-*-97	BK-M16 x 70-4pcs	264 Nm ±15%	SK-RS25RN50	SK-RS25RV50	
32	6264-10-17-*-97	BK-M18 x 75-4pcs	398 Nm ±15%	SK-RS32RN50	SK-RS32RV50	

R-RS-R4V-R6V_UK.INDD CM



R*M / R4V

4

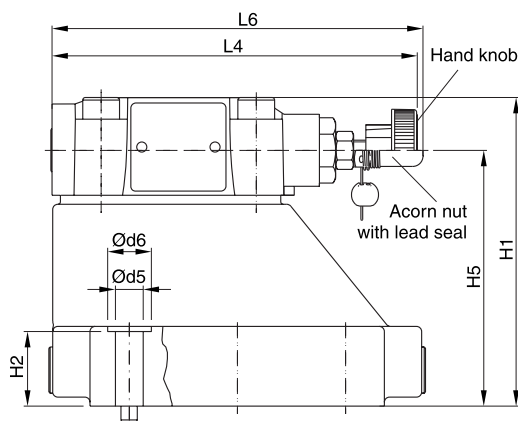
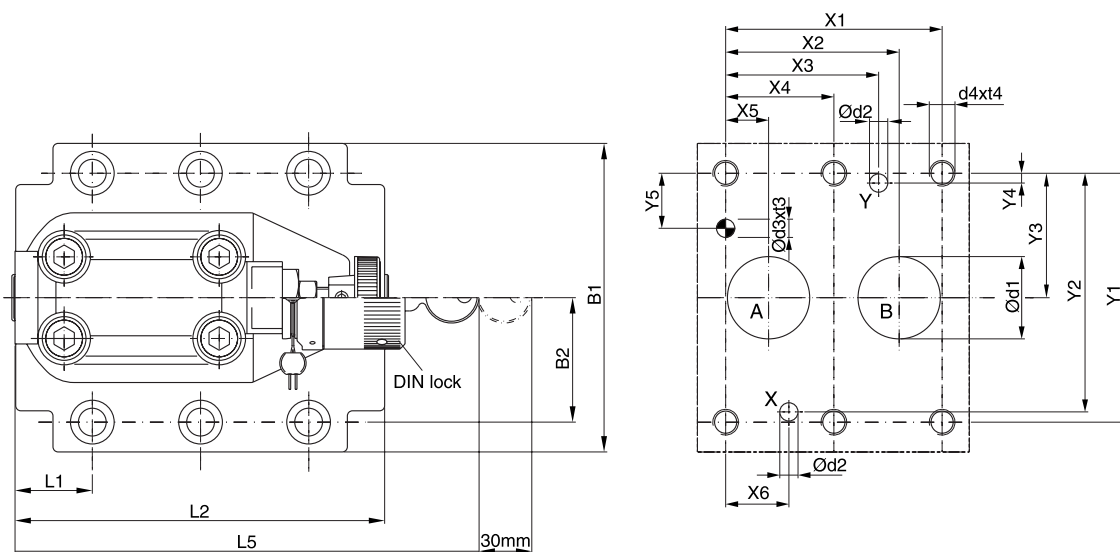



NG	ISO-code	x1	x2	x3	x4	x5	x6	x7	y1	y2	y3	y4	y5	y6
10	6264-06-07-*97	42.9	35.8	21.5	-	7.2	21.5	0	66.7	58.8	33.4	7.9	14.3	-
25	6264-08-11-*97	60.3	49.2	39.7	-	11.1	20.6	0	79.4	73	39.7	6.4	15.9	-
32	6264-10-15-*97	84.2	67.5	59.5	42.1	16.7	24.6	0	96.8	92.8	48.4	3.8	21.4	-

Tolerance at X and Y pin holes and screw holes ±0.1, at port holes ±0.2.

NG	ISO-code	B1	B2	H1	H2	H3	H4	H5	H6	L1	L2	L3	L4	L5	L6
10	6264-06-07-*97	87.3	33.35	83	21	-	-	62.5	-	29	94.8	-	143	181	144.8
25	6264-08-11-*97	105	39.7	109.5	29	-	-	89	-	34.7	126.8	-	143	181	144.8
32	6264-10-15-*97	120	48.4	120	29	-	-	99.5	-	30.6	144.3	-	143	181	144.8

NG	ISO-code	d1max	d2max	d3	t3	d4	t4	d5	d6
10	6264-06-07-*97	15	7	7.1	8	M10	16	10.8	17
25	6264-08-11-*97	23.4	7.1	7.1	8	M10	18	10.8	17
32	6264-10-15-*97	32	7.1	7.1	8	M10	20	10.8	17

NG	ISO-code	Bolt kit -  DIN912 12.9		Kit		Surface finish
				NBR	FPM	
10	6264-06-07-*97	BK-M10 x 35-4pcs	63 Nm ±15%	SK-R10MN50	SK-R10MV50	
25	6264-08-11-*97	BK-M10 x 45-4pcs	63 Nm ±15%	SK-R25MN50	SK-R25MV50	
32	6264-10-15-*97	BK-M10 x 45-6pcs	63 Nm ±15%	SK-R32MN50	SK-R32MV50	

R-RS-R4V-R6V_UK.INDD CM

RS*M / R4V with vent function

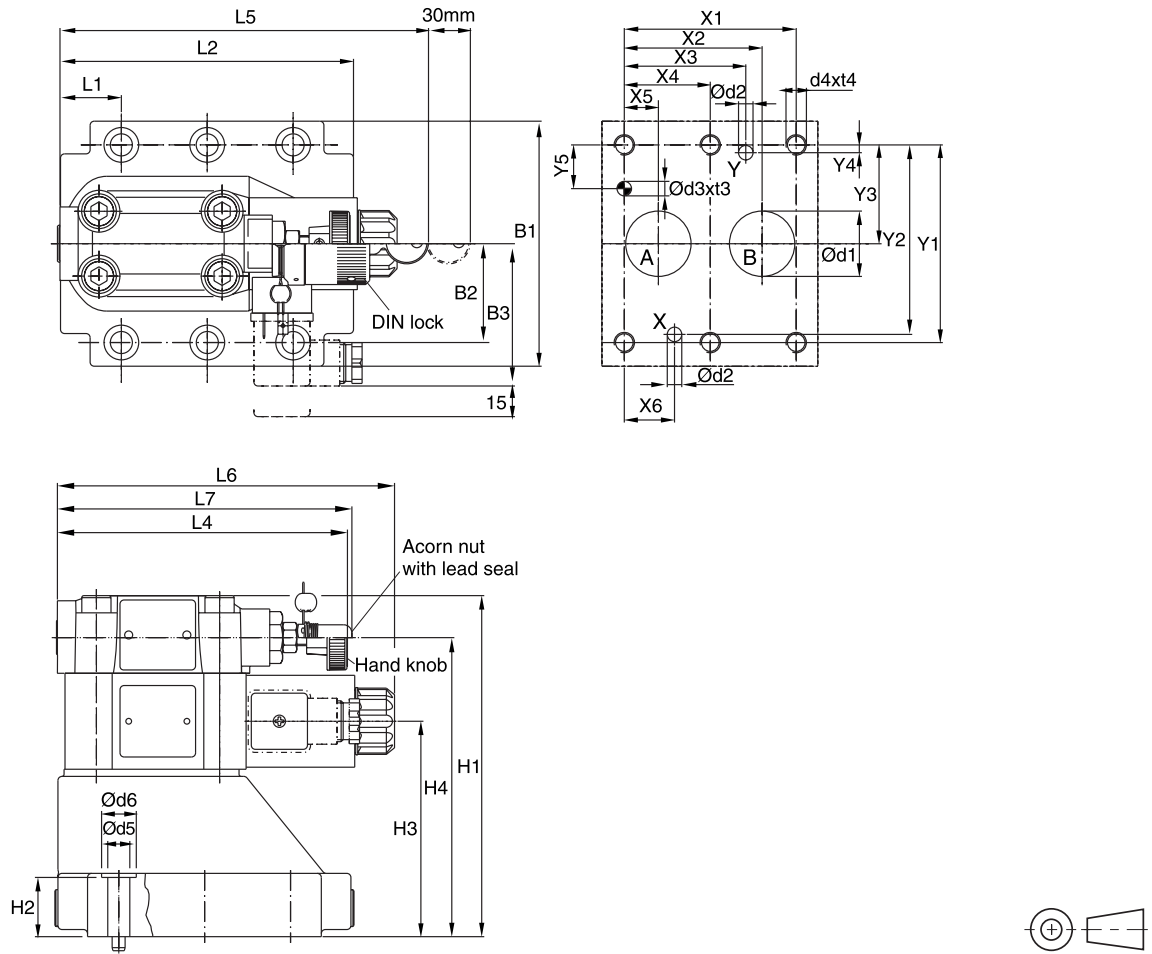

4

NG	ISO-code	x1	x2	x3	x4	x5	x6	x7	y1	y2	y3	y4	y5	y6
10	6264-0-07-*-97	42.9	35.8	21.5	–	7.2	21.5	0	66.7	58.8	33.4	7.9	14.3	–
25	6264-08-11-*-97	60.3	49.2	39.7	–	11.1	20.6	0	79.4	73	39.7	6.4	15.9	–
32	6264-10-15-*-97	84.2	67.5	59.5	42.1	16.7	24.6	0	96.8	92.8	48.4	3.8	21.4	–

Tolerance at X and Y pin holes and screw holes ±0.1, at port holes ±0.2.

NG	ISO-code	B1	B2	B3	H1	H2	H3	H4	H6	L1	L2	L3	L4	L5	L6	L7
10	6264-06-07-*-97	87.3	33.35	70	130	21	68.5	109.5	–	29	94.8	–	143	181	165.6	144.8
25	6264-08-11-*-97	105	39.7	70	156.5	29	95	136	–	34.7	126.8	–	143	181	165.6	144.8
32	6264-10-15-*-97	120	48.4	70	167	29	105.5	146.5	–	30.6	144.3	–	143	181	165.6	144.8

NG	ISO-code	d1max	d2max	d3	t3	d4	t4	d5	d6
10	6264-06-07-*-97	15	7	7.1	8	M10	16	10.8	17
25	6264-08-11-*-97	23.4	7.1	7.1	8	M10	18	10.8	17
32	6264-10-15-*-97	32	7.1	7.1	8	M10	20	10.8	17

NG	ISO-code	Bolt kit - DIN912 12.9		Kit		Surface finish
				NBR	FPM	
10	6264-06-07-*-97	BK-M10 x 35-4pcs	63 Nm ±15%	SK-RS10MN50	SK-RS10MV50	$\sqrt{R_{max}6.3}$ $\square 0.01/100$
25	6264-08-11-*-97	BK-M10 x 45-4pcs	63 Nm ±15%	SK-RS25MN50	SK-RS25MV50	
32	6264-10-15-*-97	BK-M10 x 45-6pcs	63 Nm ±15%	SK-RS32MN50	SK-RS32MV50	

R-RS-R4V-R6V_UK.INDD CM



The pilot operated pressure relief valves series DSDU limit the system pressure by opening the pressure port to the tank. They are mostly used for accumulator pressure relief. The valve is set and sealed by the German technical monitoring association TÜV. The valve delivery includes a copy of the TÜV certificate.

Features

- TÜV certificate

Parker	
• TÜV • SV • 93 • 823 •	•
d _s (mm) • F • G (l/min) • p (bar)	

- Subplate mounting acc. to ISO 6264
- Nominal size 25
- Remote control via port X

Other TÜV approved pressure relief valves on request.

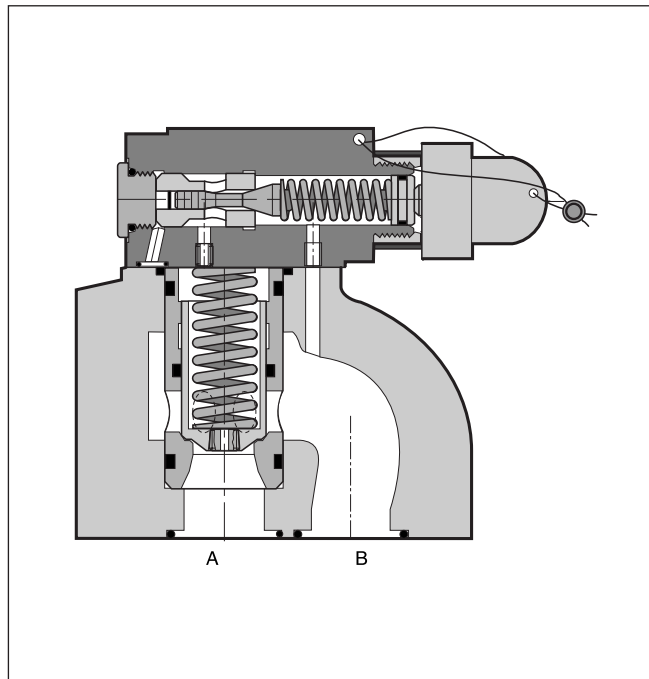
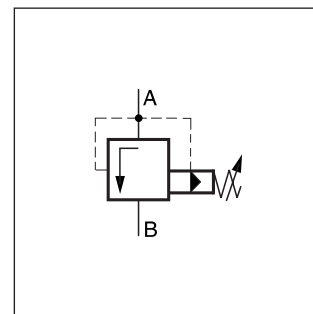

DSDU*P20

4

Technical data

General		
Size		25
Interface		Subplate mounting according to ISO 6264
Mounting position		as desired, horizontal mounting preferred
Ambient temperature	[°C]	-20...+80
Weight	[kg]	4.5
Hydraulic		
Max. operating pressure	[bar]	Ports A and X 350, B and Y depressurized
Pilot		Internal / internal
Adjustment pressure	[bar]	See ordering code
Nominal flow	[l/min]	See ordering code
Fluid		Hydraulic oil according to DIN 51524 ... 525
Viscosity, recommended permitted	[cSt] / [mm ² /s]	30 ... 50
	[cSt] / [mm ² /s]	12 ... 230
Fluid temperature	[°C]	-5 ... +70
Filtration		ISO 4406 (1999), 18/16/13

Ordering Code / p/Q Curve

Ordering code

Code	Seals
omit	NBR
V	FPM

Seals

DSDU

Type code

Pressure stage

TÜV

Desired opening pressure in bar (please specify)

Type Code 578 P20	Pressure stage	Opening pressure ranges [bar]
Q_{max} [l/min] depending on opening pressure		
220	B	50 - 75
240	E	76 - 125
265		126 - 175
300	G	176 - 200
320		201 - 250
345	K	251 - 300
370		301 - 350

Bold letters =
Short-term availability

4

Ordering Examples

- DSDU 578 P20 - 120bar matches Q_{max} 240 l/min, opening pressure 120bar
- DSDU P578 P20 - 150bar matches Q_{max} 265 l/min, opening pressure 150bar

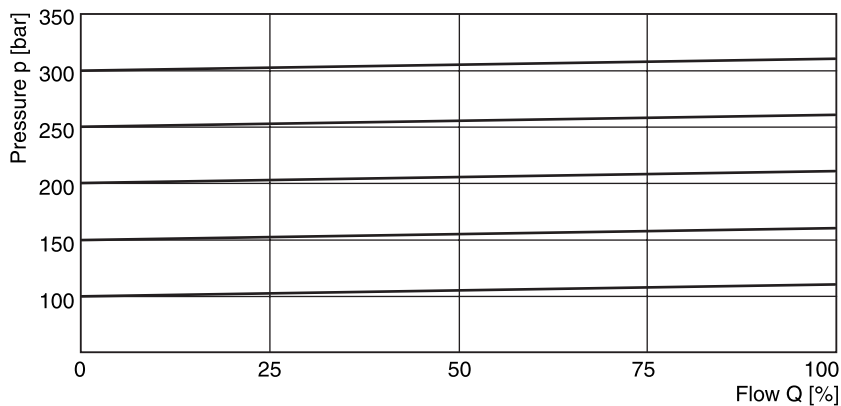

p/Q curve

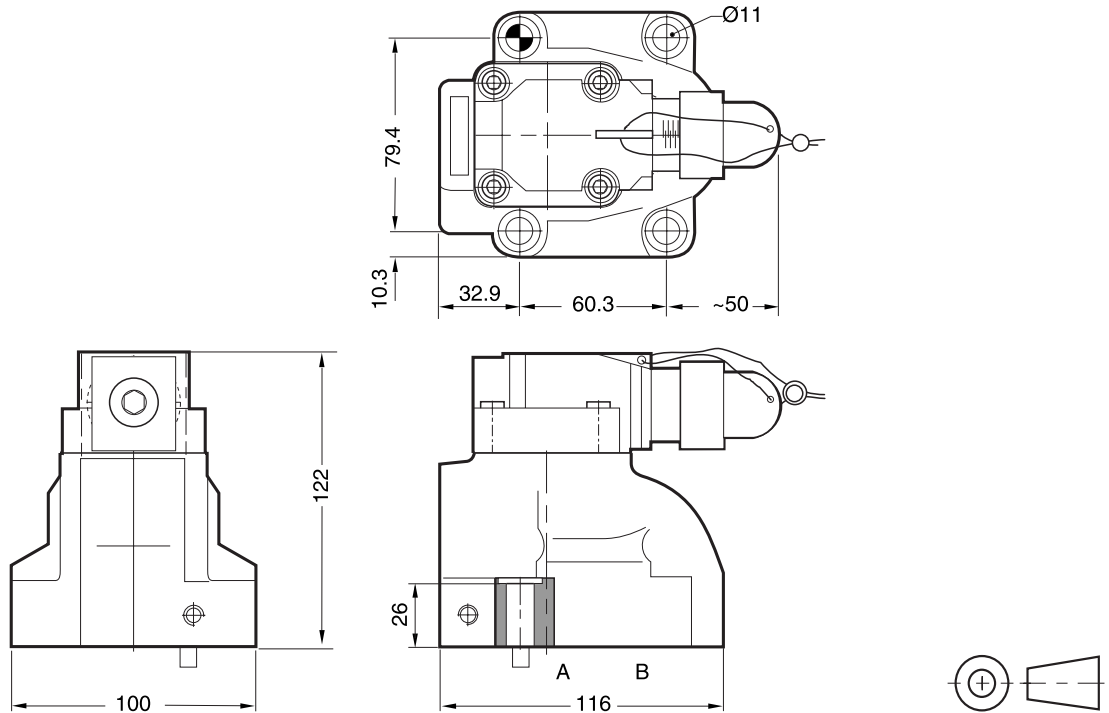

DSDU*P20



4

Size	Bolt kit -  DIN 912 12.9		NBR  Kit	FPM
P20	BK-M10 x 40-4pcs	63 Nm ±15%	SK-DSDU5P20	SK-DSDU5P20V

Mounting pattern ISO 6264-08-11-*-97

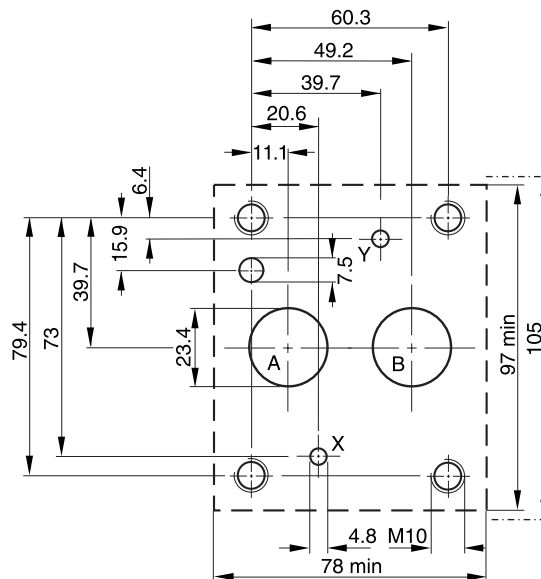

Tolerance at pin holes and screw holes ±0.1, at port holes ±0.2.

Direct operated proportional pressure relief valves are available with both Parker (series RE06M*W) and Denison (series 4VP01) model codes.

Function

When the pressure in port P (or A for RE06M*W) exceeds the pressure setting at the solenoid, the cone opens to port T and limits the pressure in port P to the adjusted level. The optimum performance can be achieved in combination with the digital amplifier module PCD00A-400.

Features

- Direct operated by proportional solenoid
- Very low pressure adjustment of p_{min}
- 2 pressure ports, A and P for RE06M*W
- 1 pressure port for 4VP01
- Subplate mounting according to ISO 6264
- 4 pressure stages

Note

The RE06M*W series is equipped with two pressure ports (port P and A). The solenoid is located on the B port side of the mounting pattern.

The 4VP01 series is equipped with one pressure port (port P). The solenoid is located on the A port side of the mounting pattern.



RE06M*W

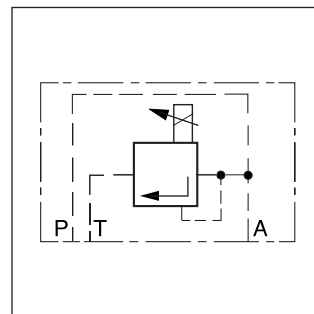

RE06M*W

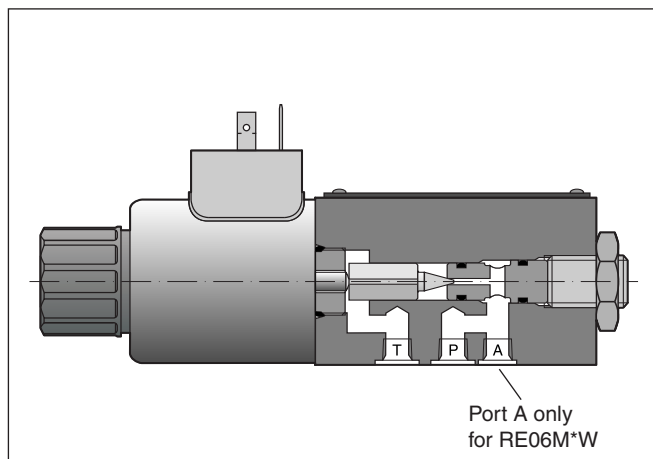

Technical data

General		
Nominal size		DIN NG06 / CETOP03 / NFPA D03
Interface		Subplate mounting according to ISO 6264
Mounting position		as desired, horizontale mounting preferred
Ambient temperature	[°C]	-20 ... +70
Weight	[kg]	1.8
Hydraulic		
Max. operating pressure	[bar]	Ports P (and A) up to 350; port T depressurized
Pressure stages	[bar]	105, 175, 250, 350
Nominal flow	[l/min]	See p/Q curves
Fluid		Hydraulic oil as per DIN 51524 ... 525
Viscosity, recommended	[cSt] / [mm²/s]	30 ... 80
permitted	[cSt] / [mm²/s]	12 ... 380
Fluid temperature	[°C]	-20 ... +60
Filtration		ISO 4406 (1999), 18/16/13
Linearity	[%]	±2.8
Repeatability	[%]	<±1
Hysteresis	[%]	±1.5 of p_{max}
Electrical		
Duty ratio	[%]	100 ED
Protection class		IP 65 in accordance with EN 60529 (plugged and mounted)
Nominal voltage	[V]	12 (2.3 A max. current), 16 (1.3 A max. current)
Coil resistance	[Ohm]	4 at 20°C
Solenoid connection		Connector as per EN 175301-803
Power amplifier, recommended		PCD00A-400

RE06MW-4VP01_UK.INDD CM

Ordering Code

Parker

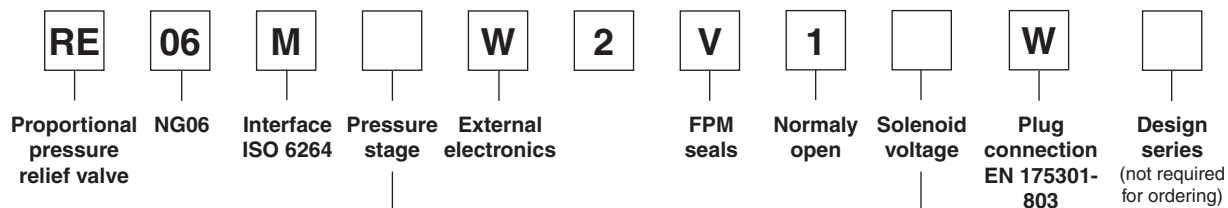

Code	Pressure stage
10	up to 105 bar
17	up to 175 bar
25	up to 250 bar
35	up to 350 bar

Code	Solenoid voltage
K	12 V, 2.3 A
X	16 V, 1.3 A

4



The Parker model code should be used for all new applications. Otherwise also refer to Denison model code.

Bold letters =
Short-term availability

Denison

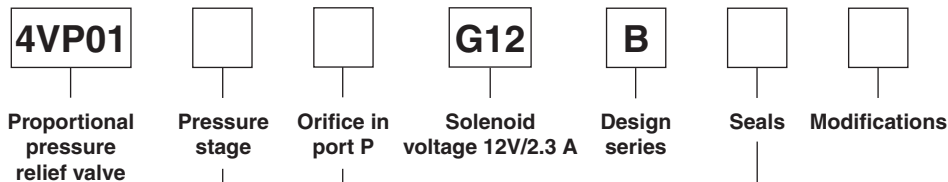

Code	Pressure stage
1	up to 50 bar
2	up to 15 bar
3	up to 210 bar
5	up to 350 bar

Code	Seals
1	NBR
5	FPM

Code	Orifice in port P
0	without (Standard)
1	Ø 0.6 mm
2	Ø 0.8 mm
3	Ø 1.0 mm
4	Ø 1.2 mm



The Denison model code is available for existing applications. Otherwise also refer to Parker model code.

p/Q curves

Pressure stage 105bar

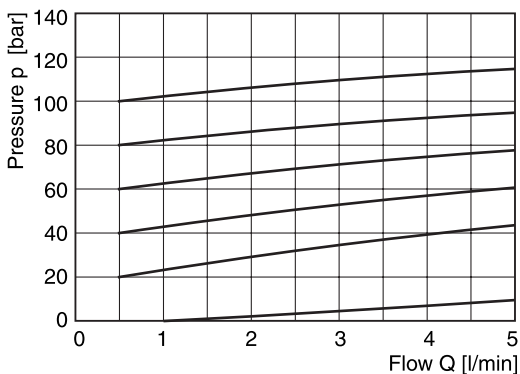

Pressure stage 350bar

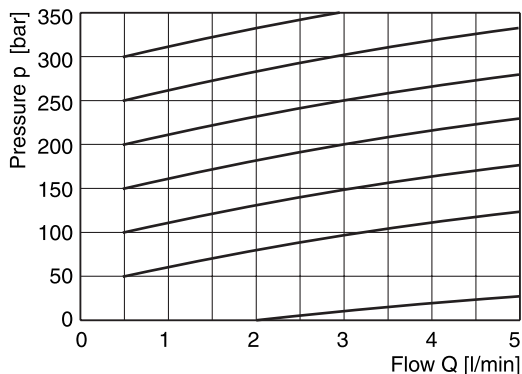

Min. adjusted pressure

Pressure stage 105bar

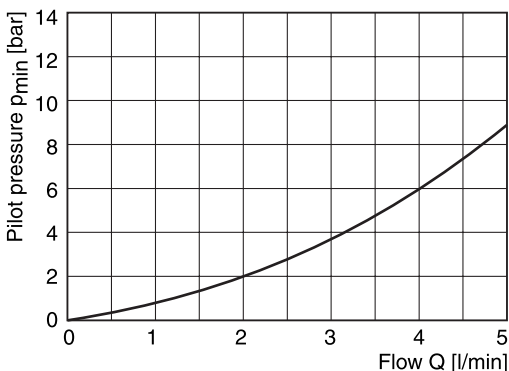

Pressure stage 350bar

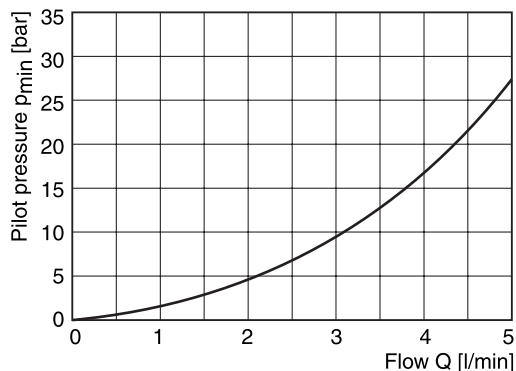

Pressure/signal curve

Pressure stage 105bar

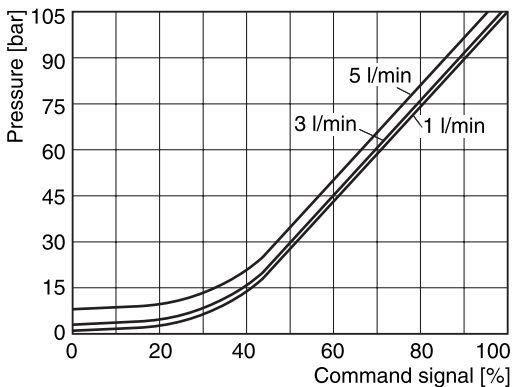

Pressure stage 350bar

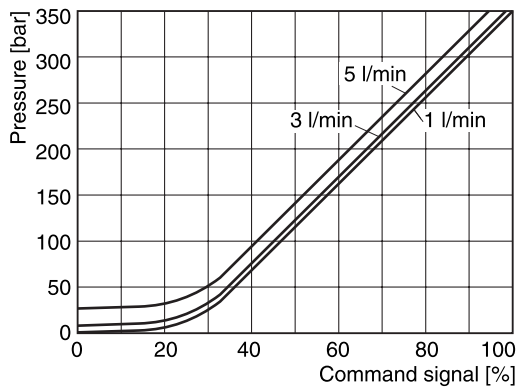

Dimensions

**Direct Operated Proportional Relief Valves
Series RE06M*W (Parker), 4VP01 (Denison)**

RE06M*W

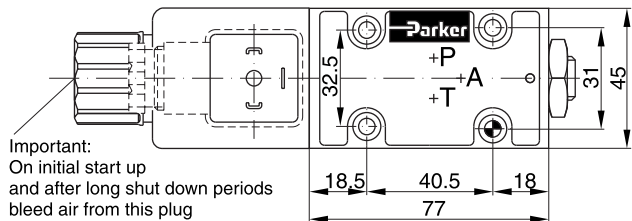

4VP01

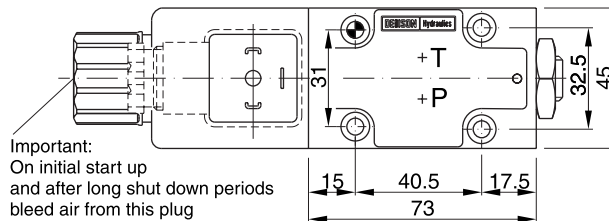

4

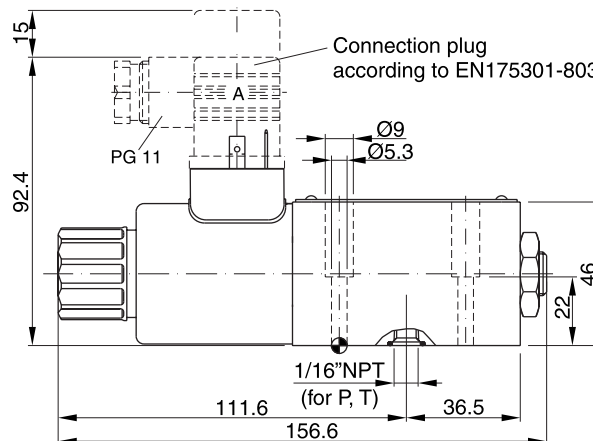
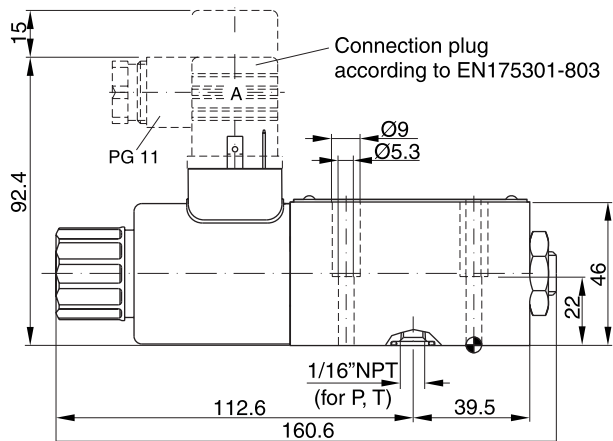

Surface finish	Bolt kit - DIN 912 12.9	Kit
	BK-4xM5x30-4pcs	NBR / FPM
	7.6 Nm ±15%	SK-RE06MNW / SK-RE06MVW

Mounting pattern ISO 6264-03-04-*-97

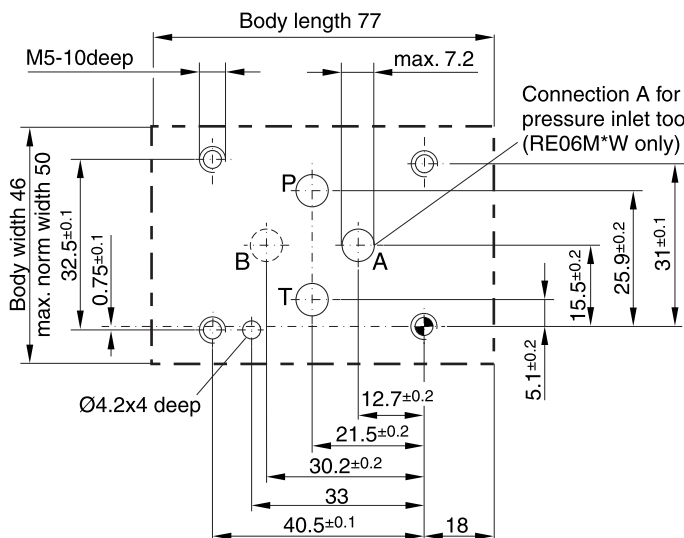

RE06M*W:
Port B: O-ring recess diameter on valve body.

4VP01:
Without ports A and B

The proportional pressure relief valve series RE06M*T is direct operated seated type valve for subplate mounting with on-board electronics.

Function

When the pressure in port P or A exceeds the pressure setting at the solenoid, the cone opens to port T and limits the inlet pressure to the adjusted level.

The pressure adjustment is effected by applying current to the solenoid. The control signal is modulated to the solenoid current by the electronics.

Features

- Direct operated pressure relief valve
- Onboard electronics
- Ramp line adjustment
- Characteristics linearized
- Very low pressure adjustment of p_{min}
- Subplate mounting acc. to ISO 6264
- 4 pressure stages
- 2 pressure inlet ports A and P

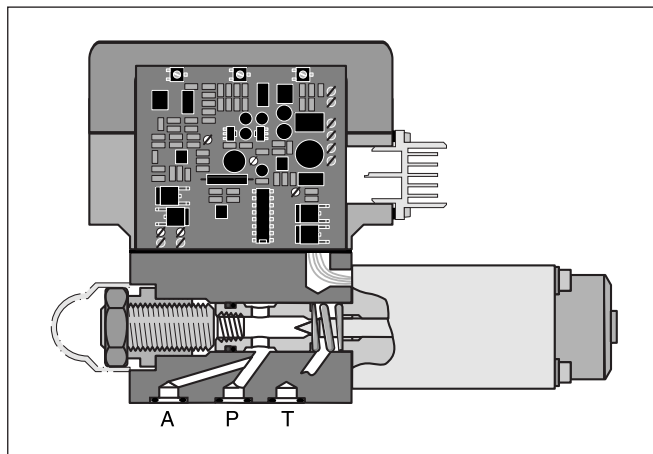
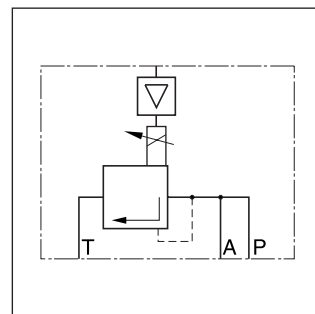

4

Ordering code

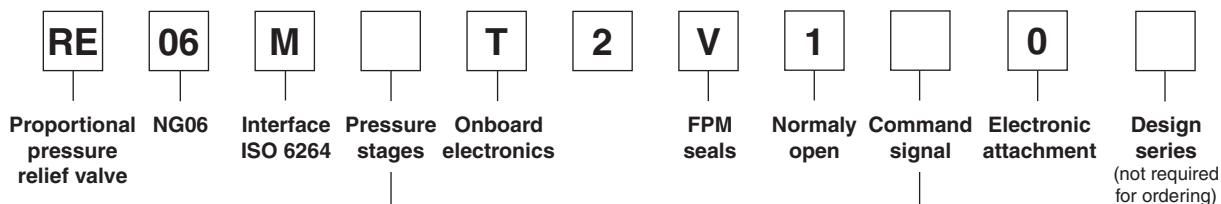

Code	Pressure stages
10	105bar
17	175bar
25	250bar
35	350bar

Bold letters = Short-term availability

Code	Command signal
F	Voltage input 0...+10V with reference output +10V
G	Current input 0...20mA

Technical Data

General		
Nominal size		DIN NG06 / CETOP03 / NFPA D03
Interface		Subplate mounting according to ISO 6264
Mounting position		as desired, horizontal mounting preferred
Ambient temperature	[°C]	-20...+80
Weight	[kg]	2.2
Hydraulic		
Max. operating pressure	[bar]	Ports A and P 350, connection T depressurized
Pressure stages	[bar]	105, 175, 250, 350
Nominal flow	[l/min]	See p/Q curves
Fluid		Hydraulic oil according to DIN 51524 ... 525
Viscosity,	recommended	[cSt] / [mm ² /s] 30 ... 80
	permitted	[cSt] / [mm ² /s] 12 ... 380
Fluid temperature	[°C]	-20 ... +60
Filtration		ISO 4406 (1999), 18/16/13
Linearity	[%]	See curve
Repeatability	[%]	<±1
Hysteresis	[%]	±1.5 of p _{max}
Electrical		
Duty ratio	[%]	100 ED
Protection class		IP65 according to EN 60529 (plugged and mounted)
Supply voltage	[V]	14.5...30
Ripple in supply voltage	[%]	max. 5
Current consumption	[A]	2.8
Input range	voltage input	[V] 0...+10 max. / 10kOhm
	current input	[mA] 0...+20 / 500Ohm
Adjustment range of ramp time	[s]	0...5
Installation cross-section		Min. 1mm ² shielded
Cable length	[m]	Max. 50
Electrical connection		No. 5004072; 6pole + PE / connector EN 175201-804 / cableØ 8...10mm

4

Signal/pressure curve

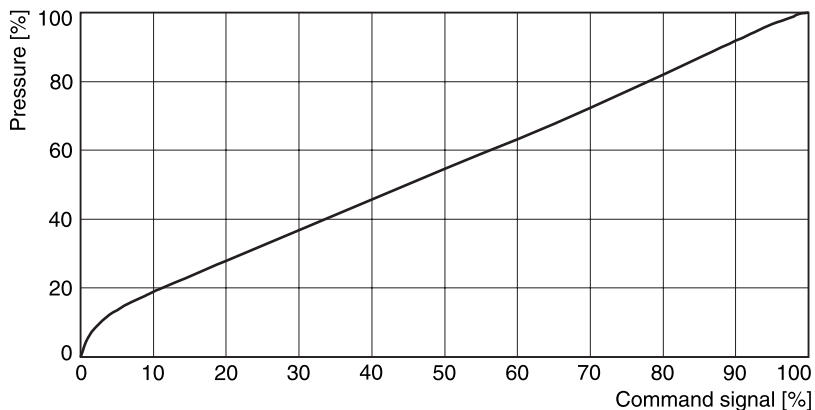

Min. adjusted pressure

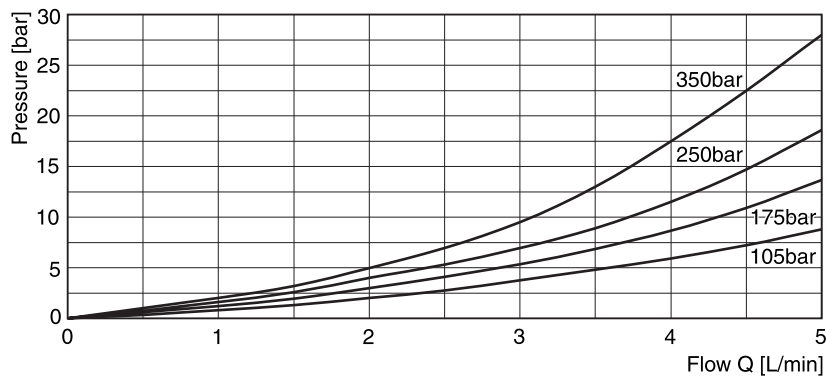

p/Q curve

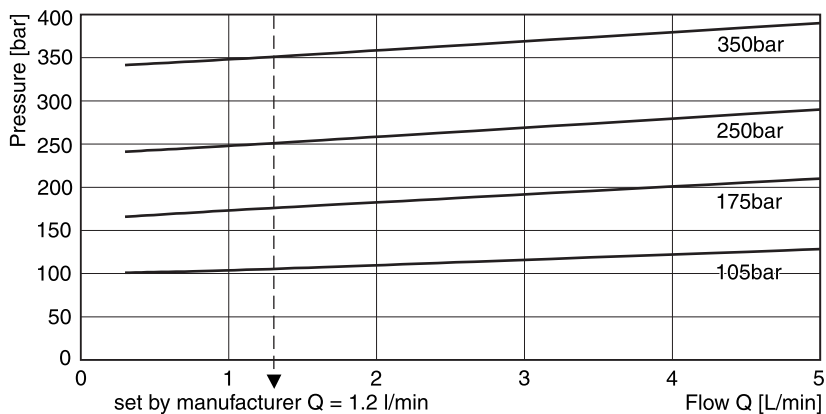

Block diagram

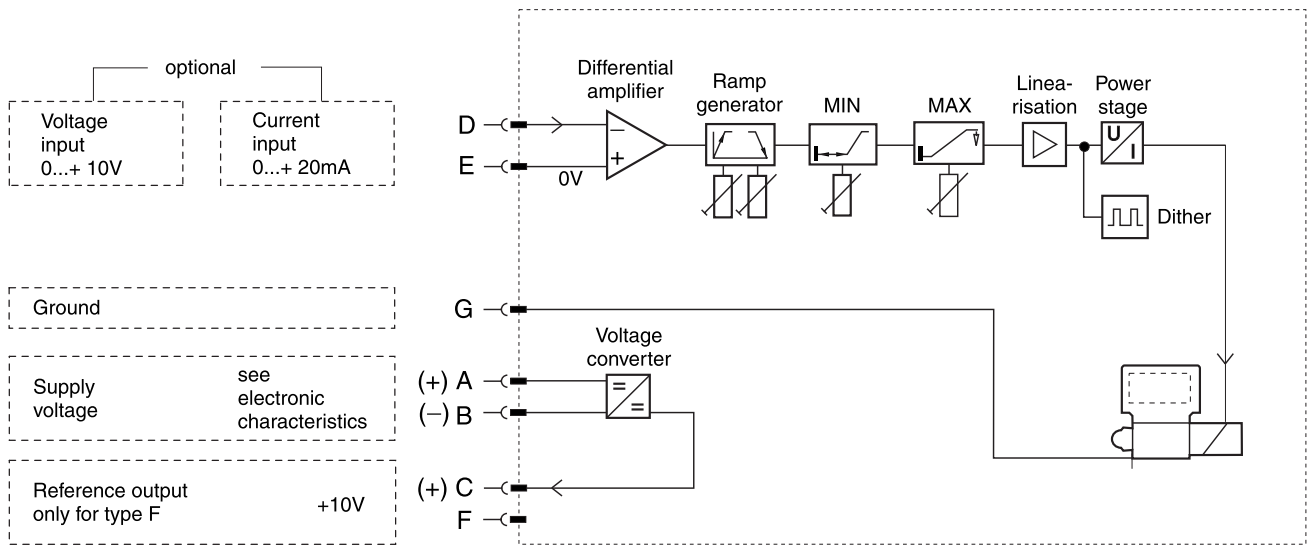

4

Connector wiring diagram

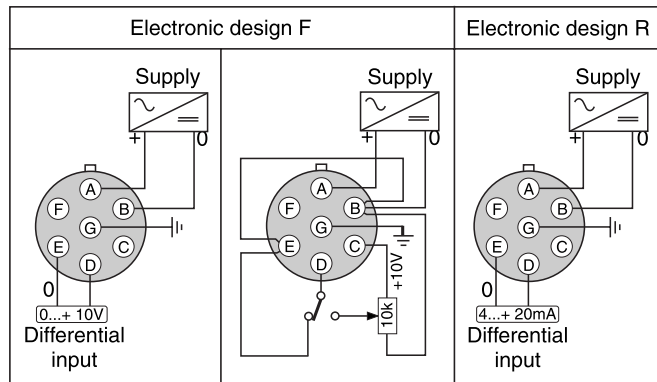

Characteristics

Proportional pressure relief valves for external electronics are available with both Parker (series RE*W) and Denison (series R*V) model codes.

A proportionally adjusted pilot stage controls a seated type main stage. The valves are equipped with a mechanical maximum pressure stage (optional for RE*R*W).

The optimum performance can be achieved in combination with the digital amplifier module PCD00A-400.

Features

- Pilot operated with proportional solenoid
- Continuous adjustment by proportional solenoid
- 2 interfaces: subplate, ISO 6264 (DIN 24340 Form D + Form E)
- 4 pressure stages
- Optional mechanical maximum pressure adjustment (for RE*R*W)

**Pilot Operated Pressure Relief Valves
Series RE*W (Parker), R*V (Denison)**



RE*R*W



RE*M*W

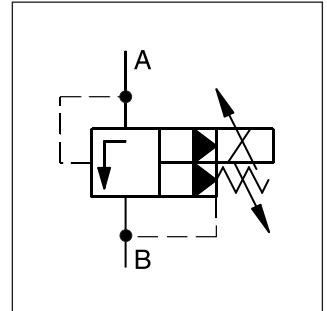
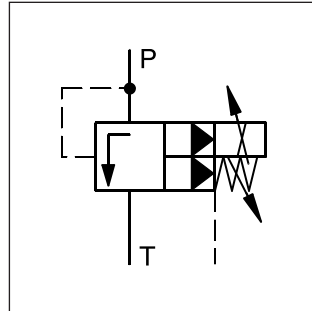

4

RE25R*W

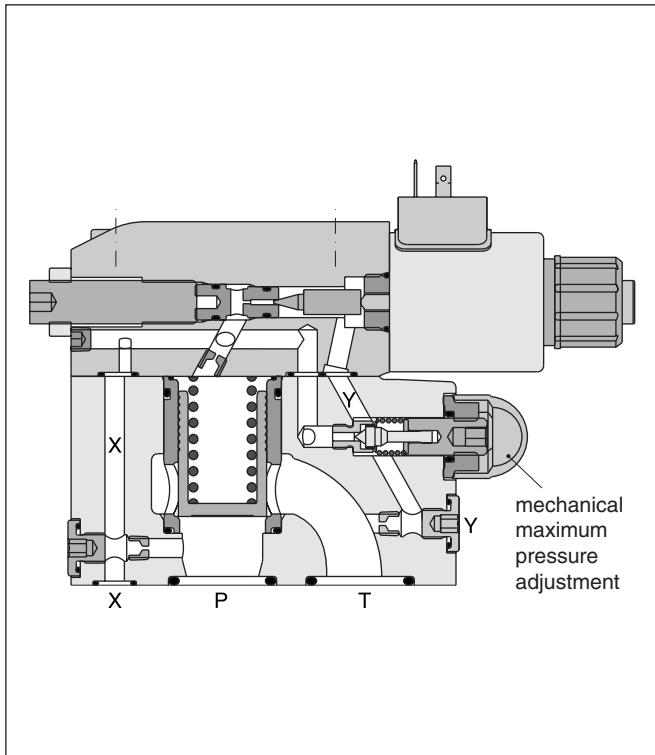

RE25M*W

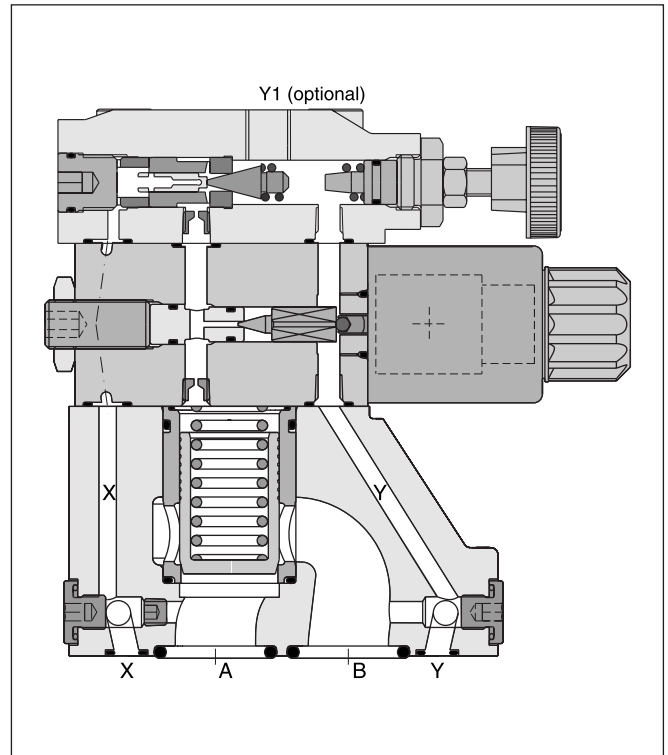

Pilot Operated Pressure Relief Valve Series RE*W (Parker)

Ordering Code

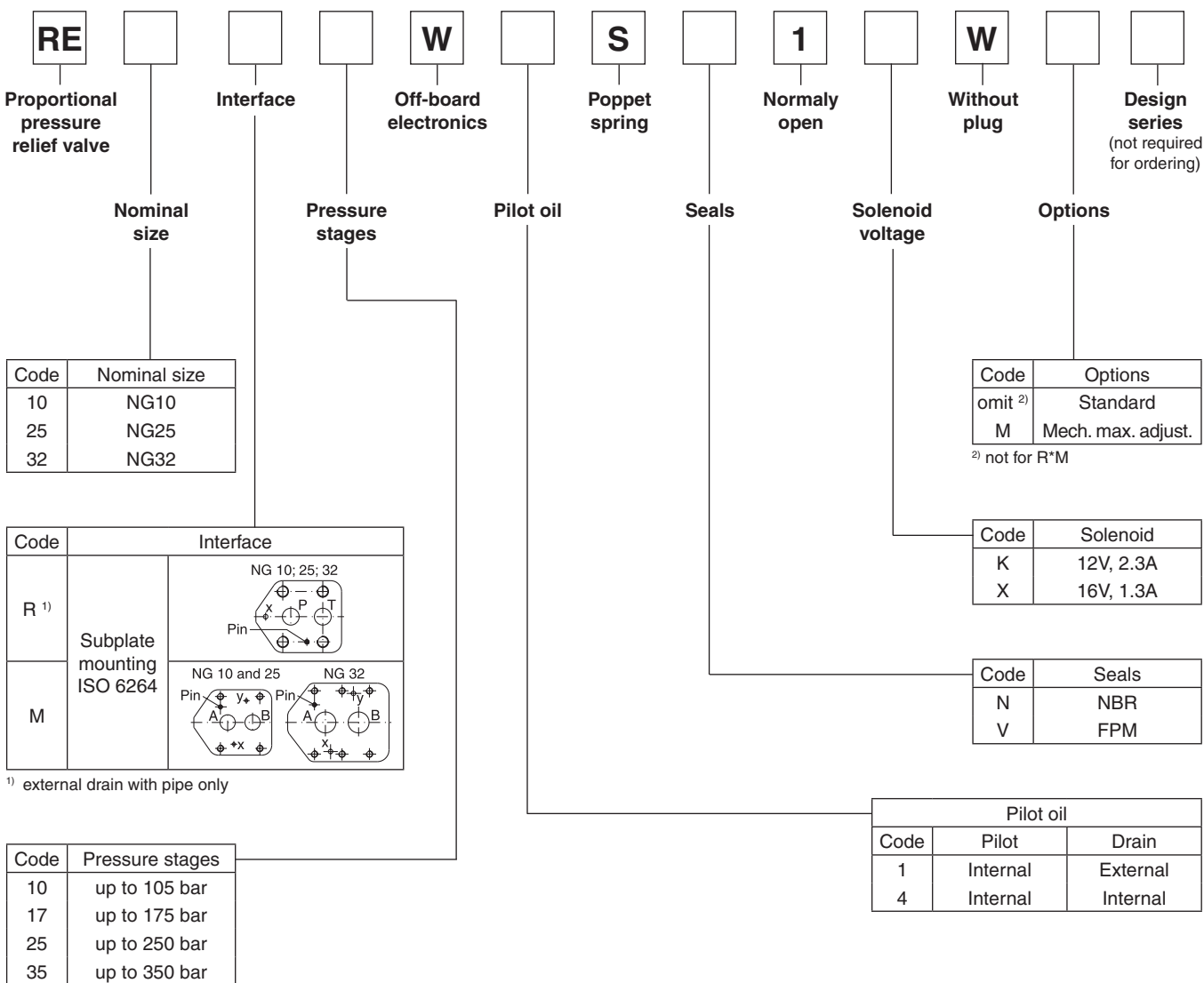

4

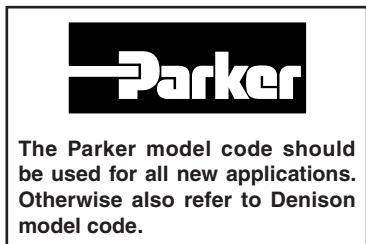

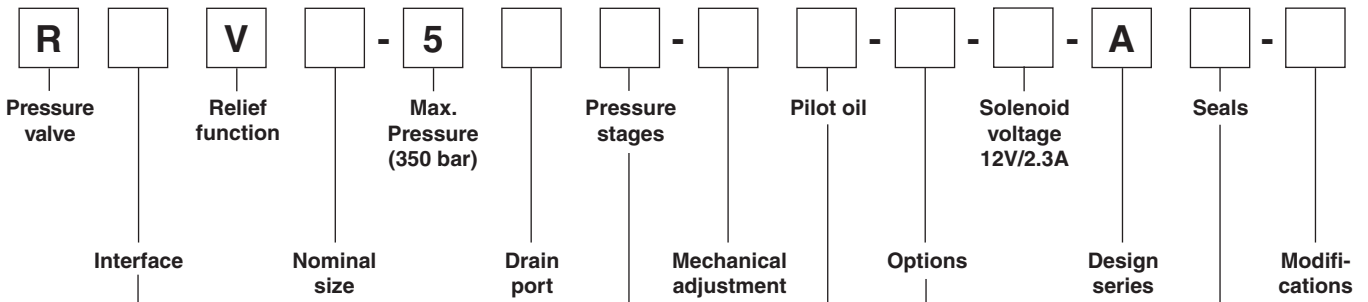

Code	Interface	
4	Subplate mounting ISO 6264	
6		

Code	Seals
1	NBR
5	FPM

Code	Nominal size
03	NG10
06	NG25
10	NG32

Code	Options
P2	With mech. max. adjustment
PS ⁴⁾	w/o mech. max. adjustment

⁴⁾ not for R4V

Code	Interface	Drain port
3	R4V	without Y-port
9	R6V	Y-port = G 1/8"

Pilot oil	
Code	Drain line
0	internal
1 ²⁾	external from subplate
2 ³⁾	external Y-port

²⁾ R4V only

³⁾ R6V only

Code	Pressure stages
1	up to 105 bar
3	up to 210 bar
5	up to 350 bar

Code	Interface	Mechanical adjustment
P ¹⁾	R6V	Hexagon screw with lock nut
1	R4V	Hand knob
3	R4V	Acorn nut with lead seal

¹⁾ Use code P also for valve w/o mechanical adjustment

4

DENISON Hydraulics

The Denison model code is available for existing applications. Otherwise also refer to Parker model code.

RE*W

General					
		10	25	32	
Nominal size					
Interface		Subplate mounting acc. ISO 6264			
Mounting position		as desired, horizontal mounting preferred			
Ambient temperature	[°C]	-20...+80			
Weight	Series RE*R	[kg]	5.2	6.4	8.3
	Series RE*M	[kg]	4.5	6.3	7.8
	Series RE*E	[kg]	—	—	—
Hydraulic					
Max. operating pressure	[bar]	Ports P (or A) and X 350, port T (or B), B and Y depressurized			
Pressure stages	[bar]	105, 175, 250, 350 (series RE*W), 105, 210, 350 (series R*V)			
Nominal flow	Series RE*R	[l/min]	250	500	650
	Series RE*M	[l/min]	150	350	650
Fluid		Hydraulic oil according to DIN 51524 ... 525			
Viscosity, recommended permitted	[cSt] / [mm ² /s]	30 ... 50			
	[cSt] / [mm ² /s]	20 ... 380			
Fluid temperature	[°C]	-20 ... +70			
Filtration		ISO 4406 (1999); 18/16/13			
Electrical (prop. solenoid)					
Duty ratio	[%]	100 ED			
Protection class		IP65 in accordance with EN 60529 (plugged and mounted)			
Nominal voltage	[V]	12 (max. current 2.3A), 16 (max. current 1.3A)			
Coil resistance	[Ohm]	4 at 20°C			
Solenoid connectors		Connector as per EN 175301-803			
Power amplifier, recommended		PCD00A-400			

4

RE*R*W/R6V

Signal/pressure curve

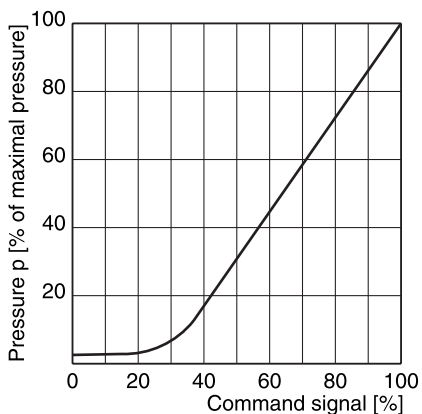

p/Q performance curves ¹⁾

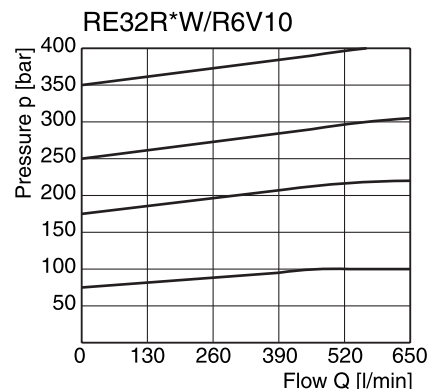
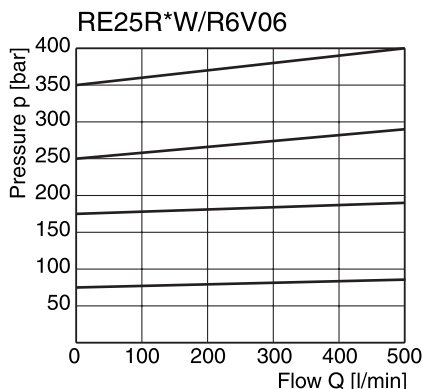
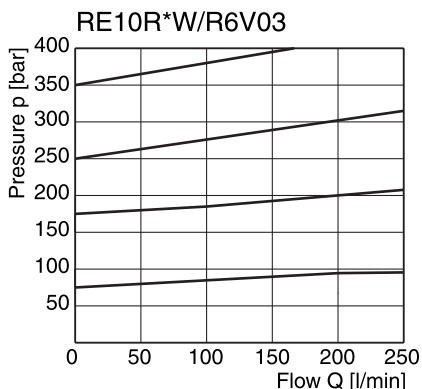

Minimum pressure curves ¹⁾

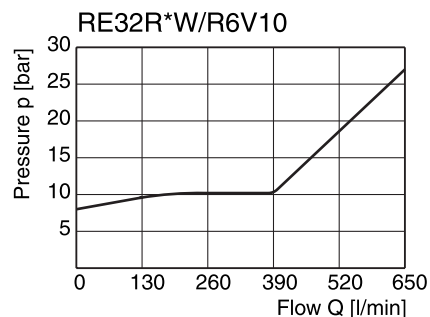
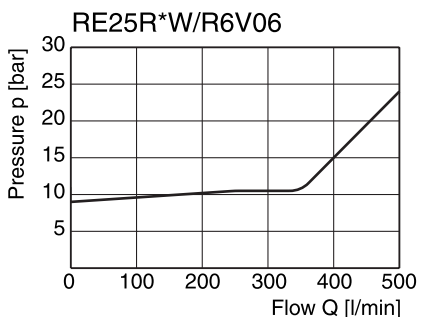
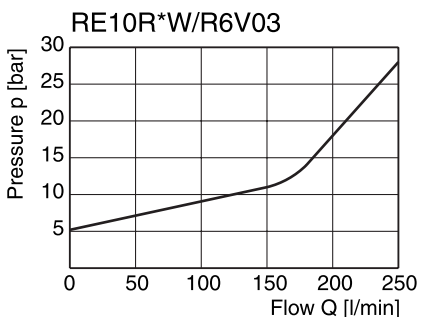

¹⁾ The performance curves are measured with external drain.
 For internal drain the tank pressure has to be added to curve.

RE*M*W/R4V

Signal/pressure curve

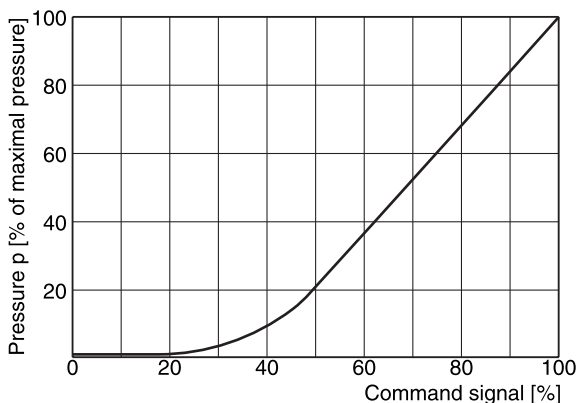

p/Q performance curves ¹⁾

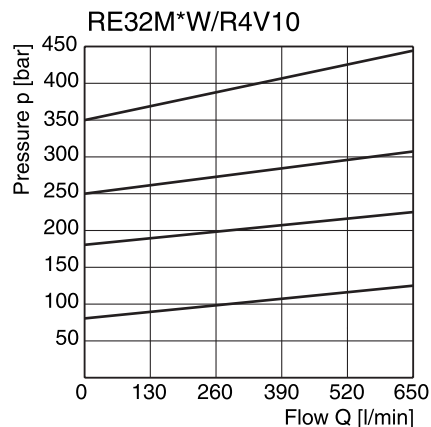
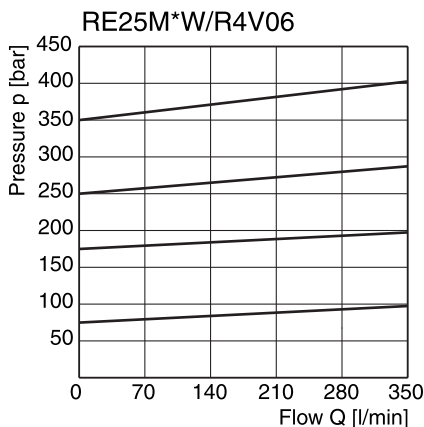
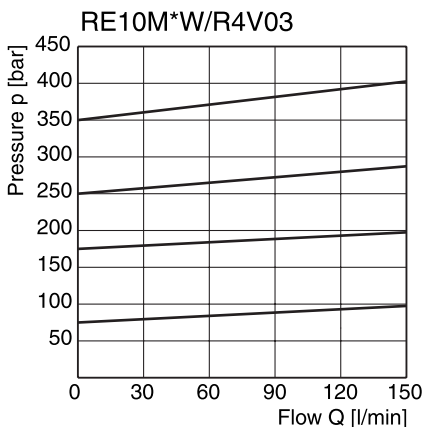

Minimum pressure curves ¹⁾

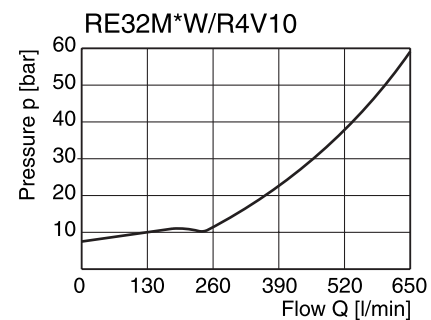
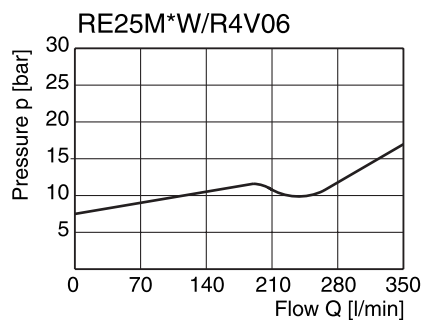
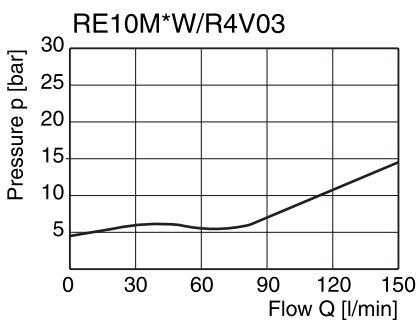

¹⁾ The performance curves are measured with external drain.
 For internal drain the tank pressure has to be added to curve.

RE*R*W/R6V

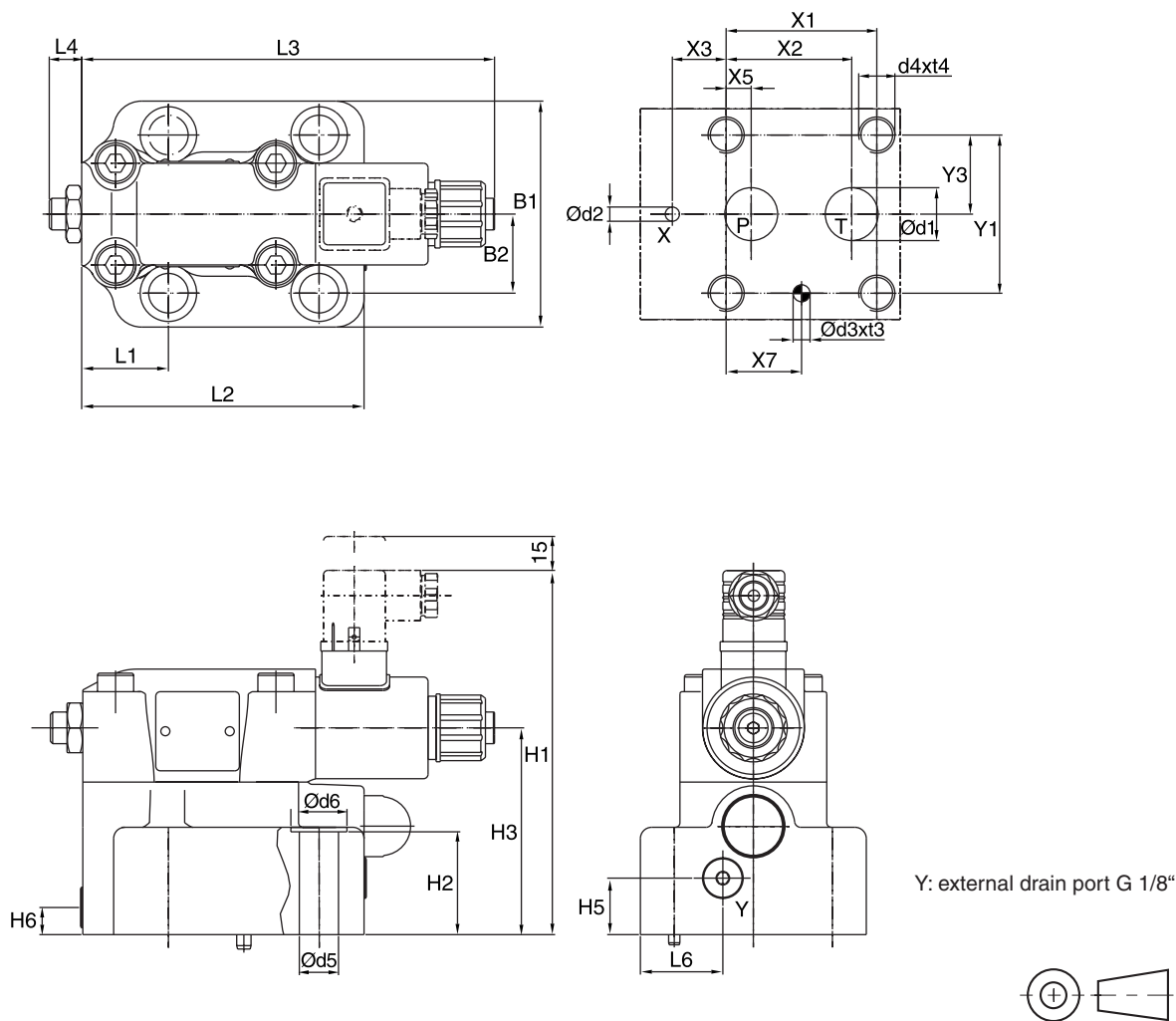



4

NG	ISO-code	x1	x2	x3	x4	x5	x6	x7	y1	y2	y3	y4	y5	y6
10	6264-06-09-*97	53.8	47.5	0	-	22.1	-	22.1	53.8	-	26.9	-	-	-
25	6264-08-13-*97	66.7	55.6	23.8	-	11.1	-	33.4	70	-	35	-	-	-
32	6264-10-17-*97	88.9	76.2	31.8	-	12.7	-	44.5	82.6	-	41.3	-	-	-

Tolerance at X and Y pin holes and screw holes ± 0.1 , at port holes ± 0.2 .

NG	ISO-code	B1	B2	H1	H2	H3	H4	H5	H6	L1	L2	L3	L4	L5	L6
10	6264-06-09-*97	80	26.9	158.7	27	88	-	20.5	25	52.5	118.5	182.3	14.4	-	29.5
25	6264-08-13-*97	100	35	161.2	45.5	91.5	-	25	12	37.9	124.5	182.3	14.4	-	36.5
32	6264-10-17-*97	120	41.3	166.7	52	97	-	26.5	13.5	45	153	182.3	14.4	-	46.5

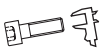
NG	ISO-code	d1max	d2max	d3	t3	d4	t4	d5	d6
10	6264-06-09-*97	14.7	4.8	7.5	10	M12	20	13.5	20
25	6264-08-13-*97	23.4	6.3	7.5	10	M16	27	17.5	25
32	6264-10-17-*97	32	6.3	7.5	10	M18	28	20	30

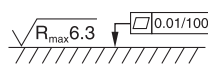
NG	ISO-code	Bolt kit -  DIN912 12.9 	Kit 		Surface finish 
			NBR	FPM	
10	6264-06-09-*97	BK-M12 x 45-4pcs	108 Nm $\pm 15\%$	SK-RE10RN50	SK-RE10RV50
25	6264-08-13-*97	BK-M16 x 70-4pcs	264 Nm $\pm 15\%$	SK-RE25RN50	SK-RE25RV50
32	6264-10-17-*97	BK-M18 x 75-4pcs	398 Nm $\pm 15\%$	SK-RE32RN50	SK-RE32RV50

REW_R4V-R6V_UK.INDD CM

RE*M*W

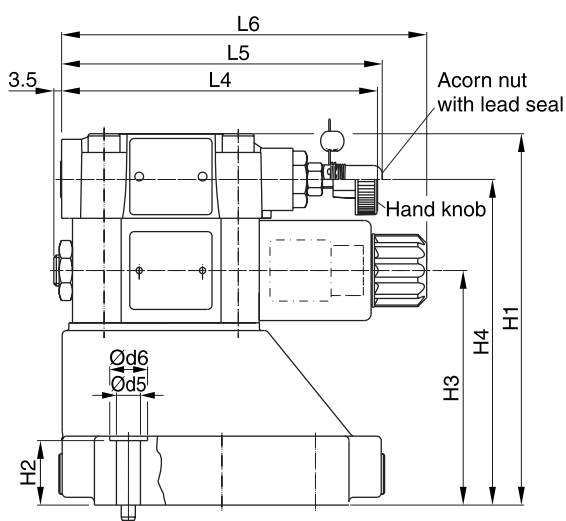
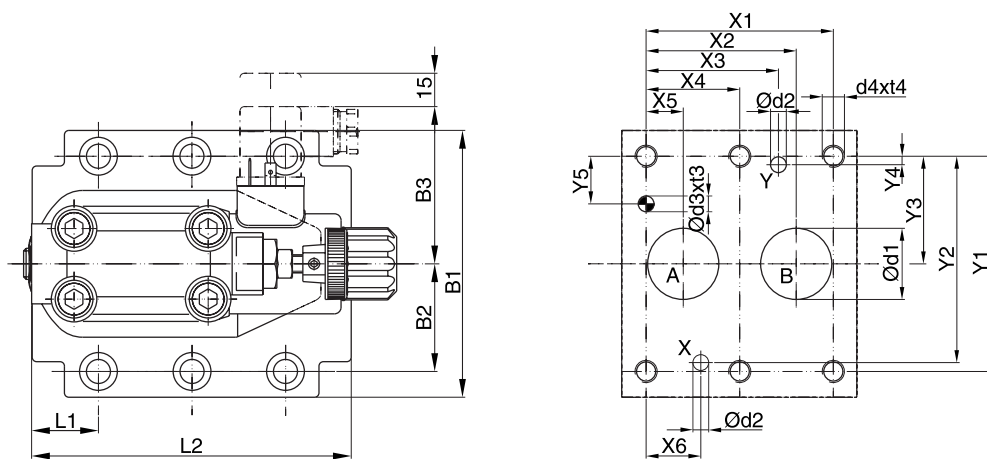



NG	ISO-code	x1	x2	x3	x4	x5	x6	x7	y1	y2	y3	y4	y5	y6
10	6264-06-07-*97	42.9	35.8	21.5	–	7.2	21.5	0	66.7	58.8	33.4	7.9	14.3	–
25	6264-08-11-*97	60.3	49.2	39.7	–	11.1	20.6	0	79.4	73	39.7	6.4	15.9	–
32	6264-10-15-*97	84.2	67.5	59.5	42.1	16.7	24.6	0	96.8	92.8	48.4	3.8	21.4	–

Tolerance at X and Y pin holes and screw holes ± 0.1 , at port holes ± 0.2 .

NG	ISO-code	B1	B2	B3	H1	H2	H3	H4	H6	L1	L2	L3	L4	L5	L6
10	6264-06-07-*97	87.3	33.35	71	130	21	68.5	109.5	–	29	94.8	–	143	144.8	164.8
25	6264-08-11-*97	105	39.7	71	156.5	29	95	136	–	34.7	126.8	–	143	144.8	164.8
32	6264-10-15-*97	120	48.4	71	167	29	105.5	146.5	–	30.6	144.3	–	143	144.8	164.8

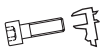
NG	ISO-code	d1max	d2max	d3	t3	d4	t4	d5	d6
10	6264-06-07-*97	15	7	7.1	8	M10	16	10.8	17
25	6264-08-11-*97	23.4	7.1	7.1	8	M10	18	10.8	17
32	6264-10-15-*97	32	7.1	7.1	8	M10	20	10.8	17

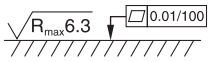
NG	ISO-code	Bolt kit -  DIN912 12.9		Kit		Surface finish
				NBR	FPM	
10	6264-06-07-*97	BK-M10 x 35-4pcs	63 Nm $\pm 15\%$	SK-RE10MN50	SK-RE10MV50	
25	6264-08-11-*97	BK-M10 x 45-4pcs	63 Nm $\pm 15\%$	SK-RE25MN50	SK-RE25MV50	
32	6264-10-15-*97	BK-M10 x 45-4pcs	63 Nm $\pm 15\%$	SK-RE32MN50	SK-RE32MV50	

REW_R4V-R6V_UK.INDD CM

Characteristics

**Proportional Pressure Relief Valves
Series RE*T (Parker), R*V (Denison)**

Proportional pressure relief valves with onboard electronics are available with both Parker (series RE*T) and Denison (series R*V) model codes.

The proportional solenoid operated pilot stage with integrated electronics controls a seated type main stage.

Features

- Pilot operated pressure relief valve
- Onboard electronics
- Factory set
- Ramp time adjustment
- Linearized characteristics
- 4 pressure stages
- 2 interfaces: subplate, ISO 6264 (DIN 24340 Form D + Form E)
- Optional mechanical maximum pressure adjustment

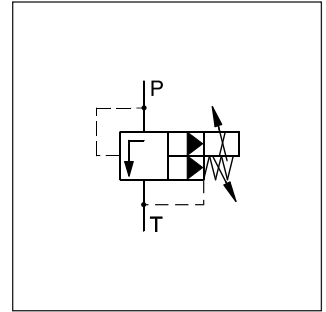
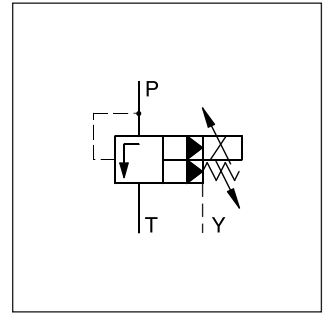

4

RE25M*T

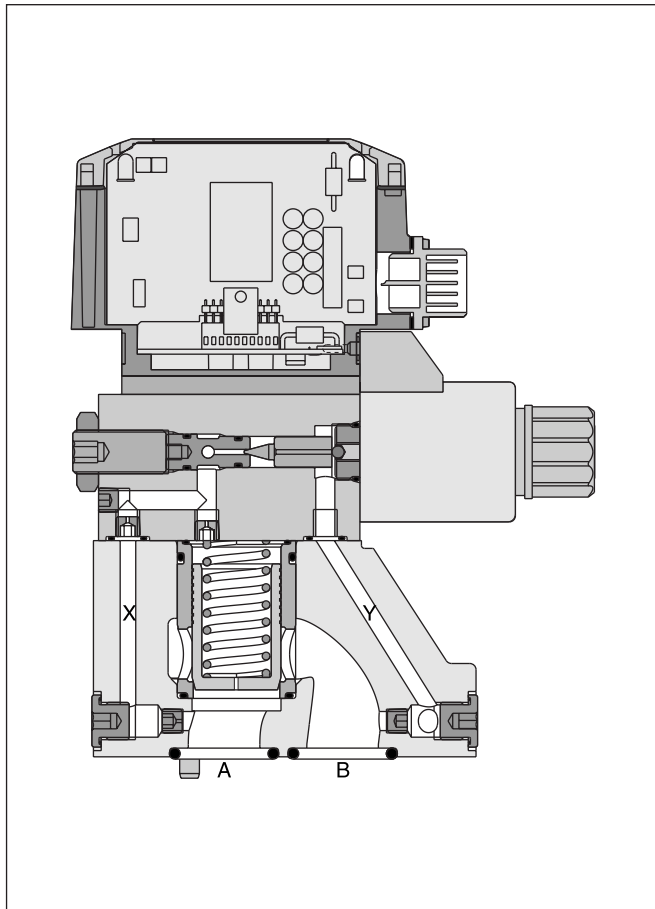

R25R*T

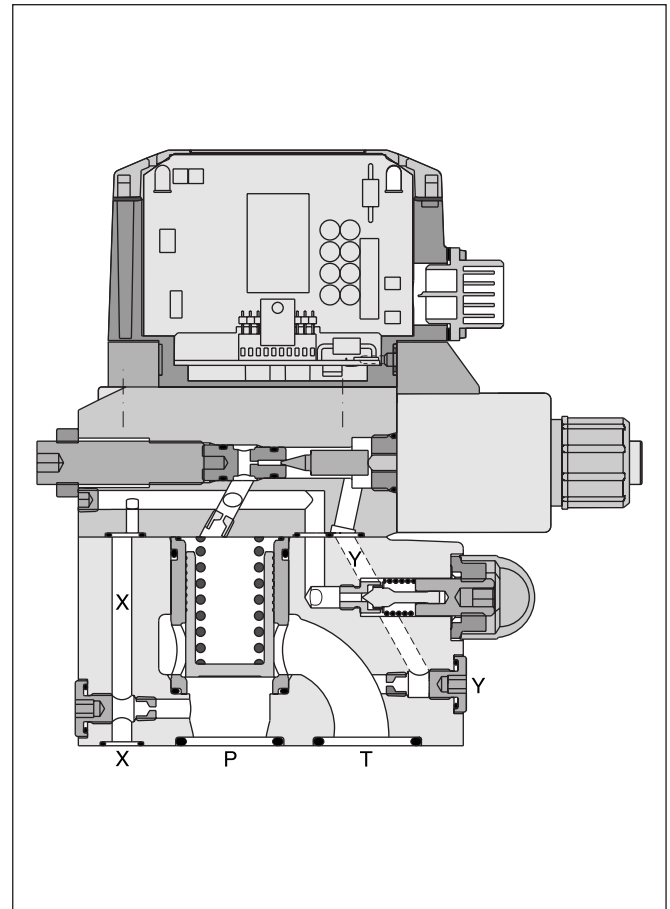

4

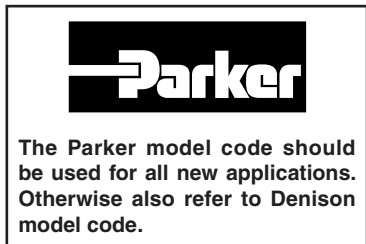
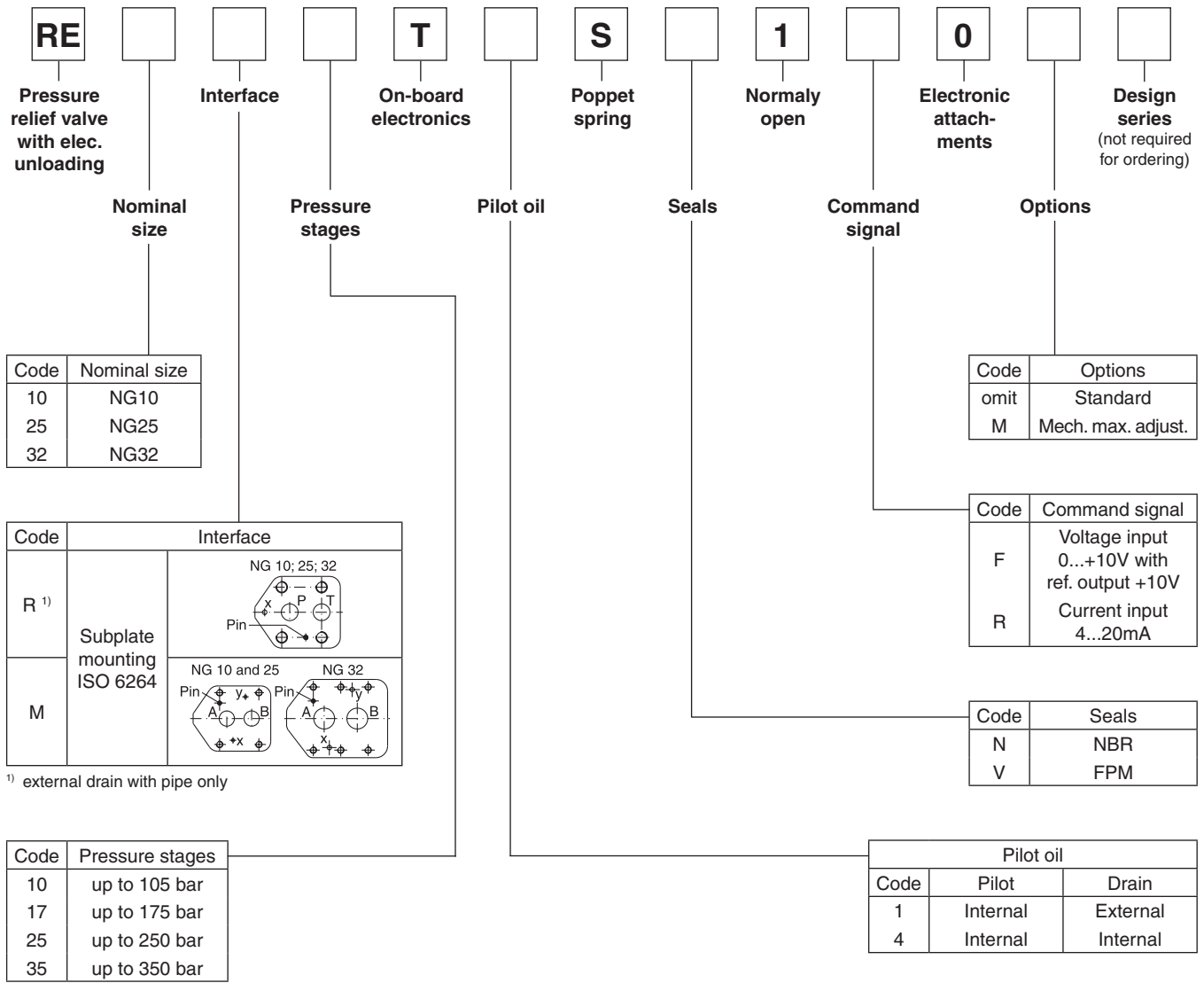

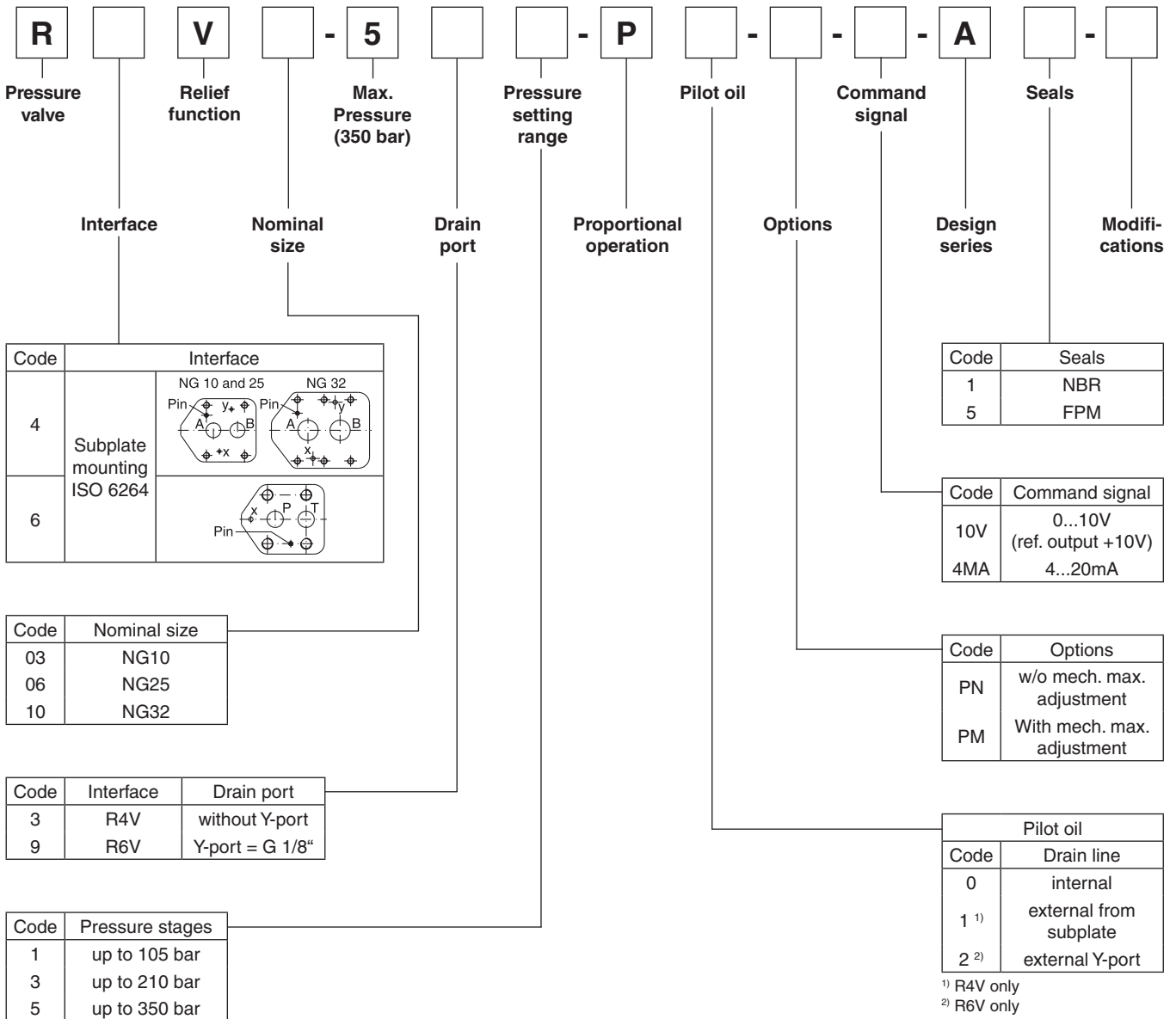

4

DENISON Hydraulics

The Denison model code is available for existing applications. Otherwise also refer to Parker model code.

RE*R/M/E*T

General					
		10	25	32	
Nominal size					
Interface		Subplate mounting acc. ISO 6264			
Mounting position		as desired, horizontal mounting preferred			
Ambient temperature	[°C]	-20...+80			
Weight	Series RE*R	[kg]	5.4	6.6	8.6
	Series RE*M	[kg]	4.5	6.3	7.8
	Series RE*E	[kg]	—	—	—
Hydraulic					
Max. operating pressure	[bar]	Ports P (or A) and X 350, port T (or B) and Y depressurized			
Pressure stages	[bar]	105, 175, 250, 350 (series RE*T), 105, 210, 350 (series R*V)			
Nominal flow	Series RE*R	[l/min]	250	500	650
	Series RE*M	[l/min]	150	350	650
Fluid		Hydraulic oil according to DIN 51524 ... 525			
Viscosity, recommended permitted	[cSt] / [mm ² /s]	30 ... 50			
	[cSt] / [mm ² /s]	20 ... 380			
Fluid temperature	[°C]	-20 ... +70			
Filtration		ISO 4406 (1999); 18/16/13			
Electrical (prop. solenoid)					
Duty ratio	[%]	100 ED			
Protection class		IP65 in accordance with EN 60529 (plugged and mounted)			
Supply voltage	[V]	14.5...30			
Ripple in supply voltage	[%]	max. 5			
Current consumption	[A]	max. 2.8			
Input range	voltage input	[V]	0...+10 max. / 10kOhm		
	current input	[mA]	0...+20 / 500Ohm		
Adjustm. range of ramp time	[s]	0...5			
Installation cross-section		Min. 1mm ² shielded			
Cable length	[m]	Max. 50			
Electrical connection		No. 5004072; 6pole + PE / connector EN 175201-804 / cableØ 8...10mm			

4

RE*R*T/R6V

Command/pressure curve

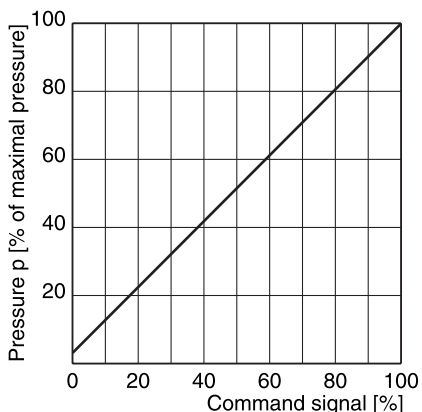

p/Q performance curves ¹⁾

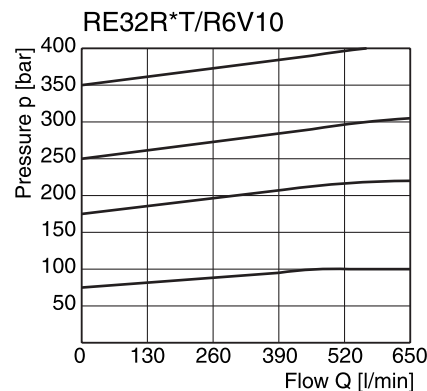
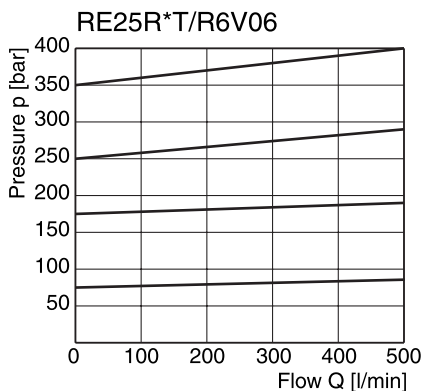
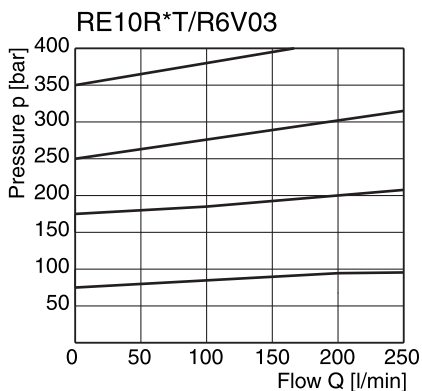

Minimum pressure curves ¹⁾

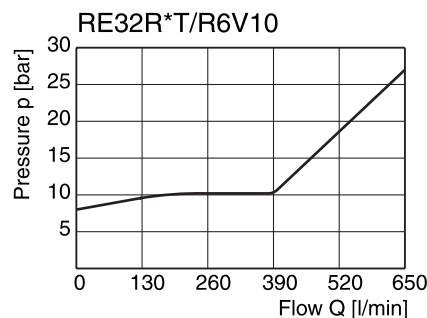
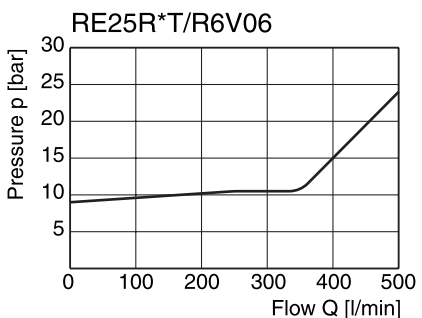
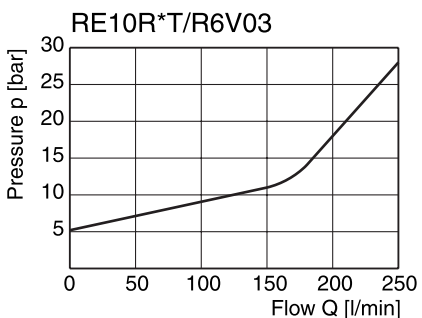

¹⁾ The performance curves are measured with external drain.
 For internal drain the tank pressure has to be added to curve.

RE*M*T/R4V

Command/pressure curve

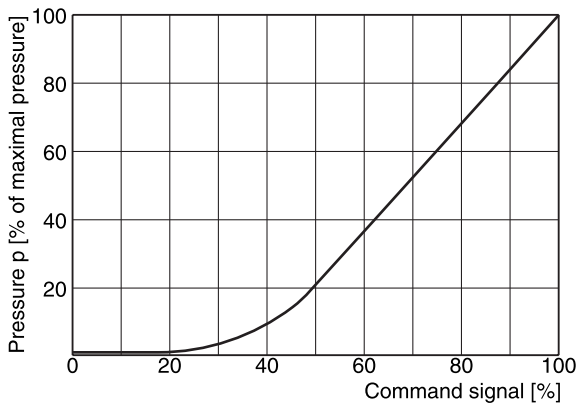

p/Q performance curves ¹⁾

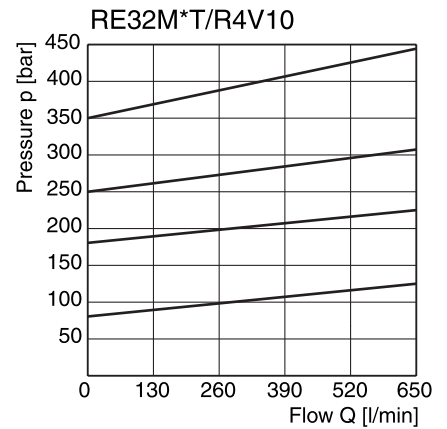
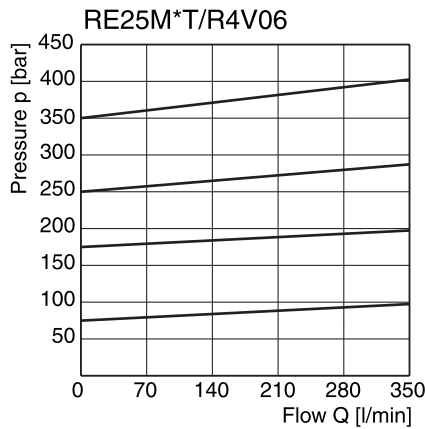
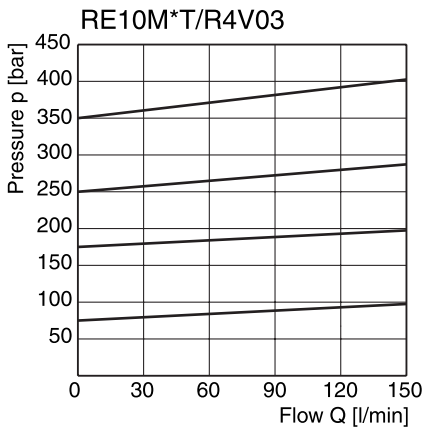

Minimum pressure curves ¹⁾

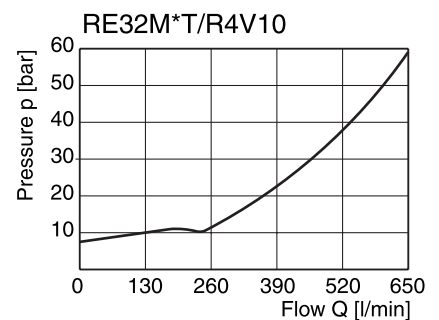
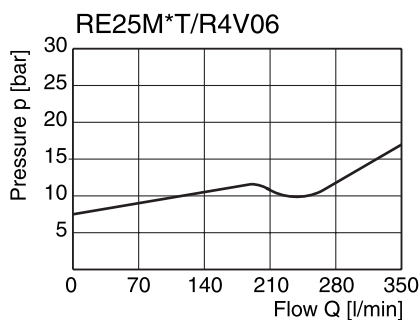
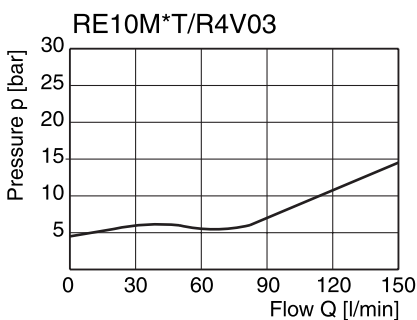

¹⁾ The performance curves are measured with external drain.
 For internal drain the tank pressure has to be added to curve.

Block diagram

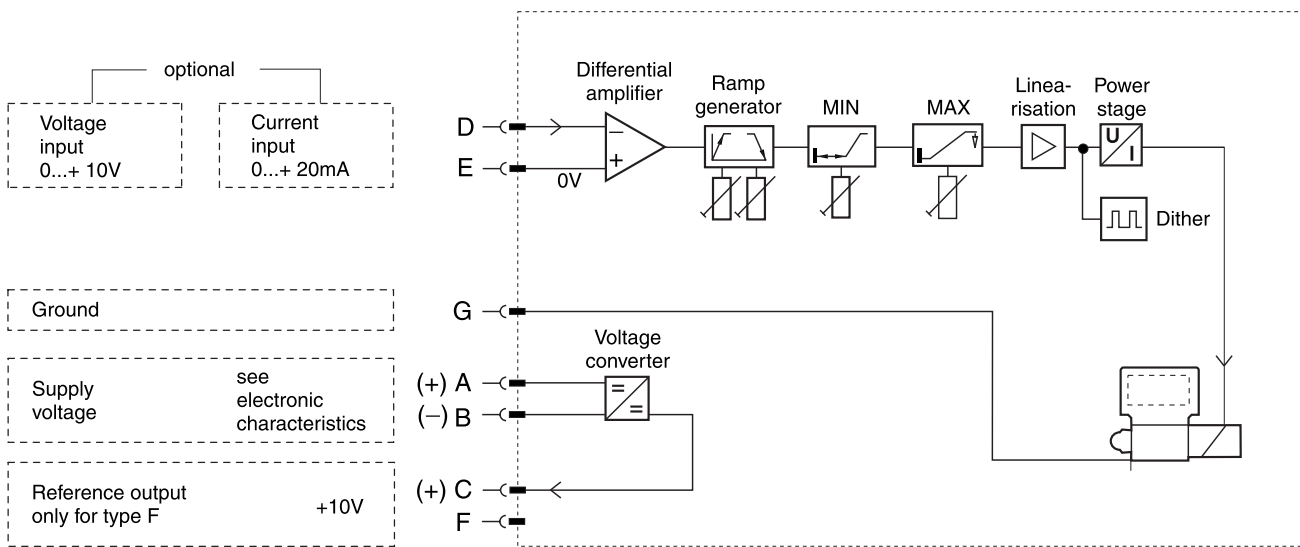

4

Connector wiring diagram

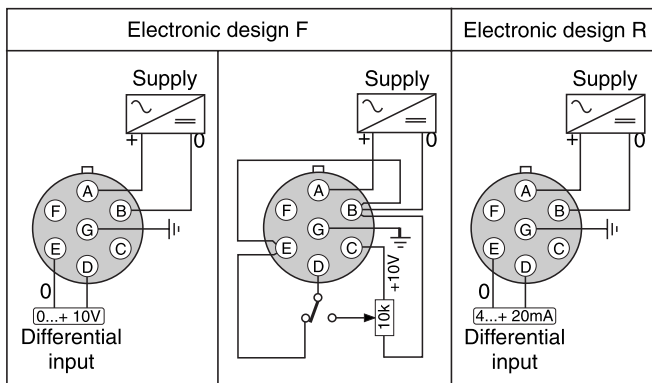

RE*R*T/R6V

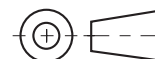
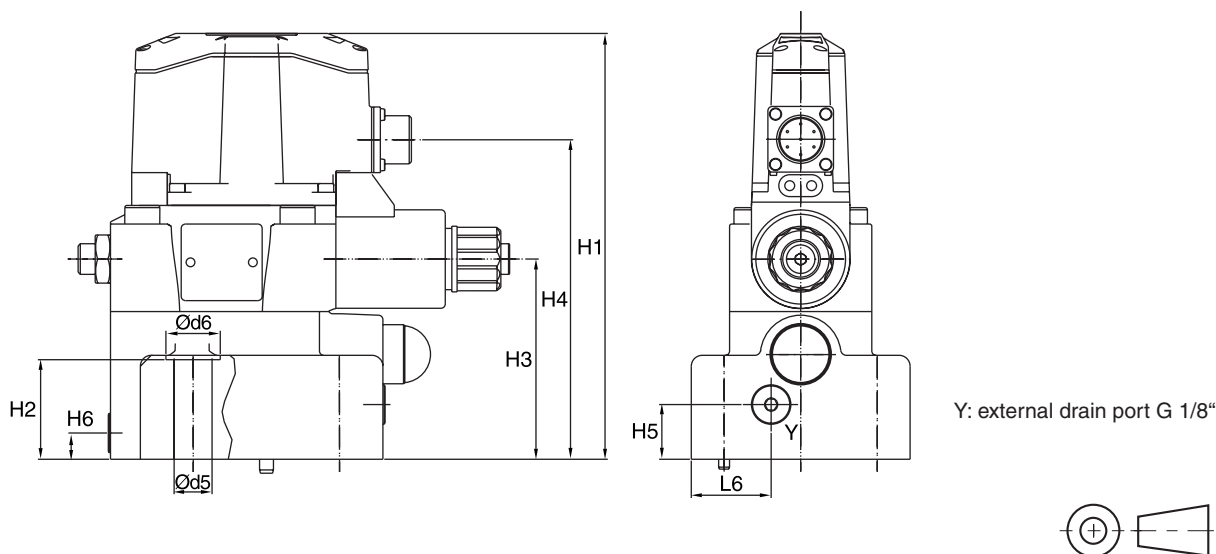
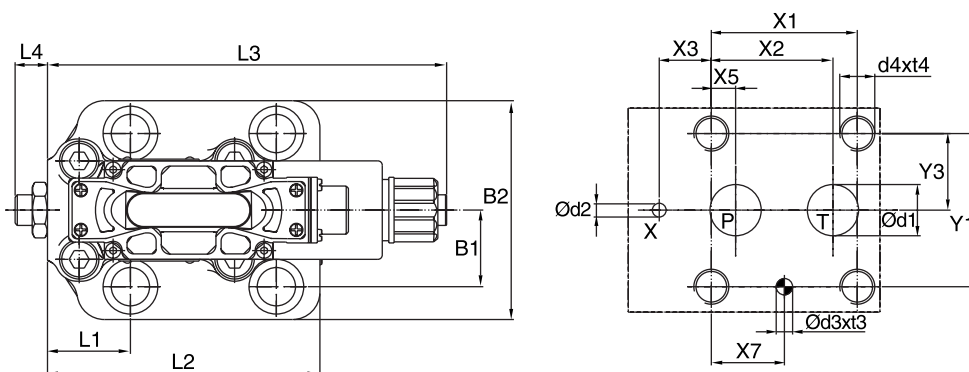

NG	ISO-code	x1	x2	x3	x4	x5	x6	x7	y1	y2	y3	y4	y5	y6
10	6264-06-09-*97	53.8	47.5	0	-	22.1	-	22.1	53.8	-	26.9	-	-	-
25	6264-08-13-*97	66.7	55.6	23.8	-	11.1	-	33.4	70	-	35	-	-	-
32	6264-10-17-*97	88.9	76.2	31.8	-	12.7	-	44.5	82.6	-	41.3	-	-	-

Tolerance at X and Y pin holes and screw holes ±0.1, at port holes ±0.2.

NG	ISO-code	B1	B2	H1	H2	H3	H4	H5	H6	L1	L2	L3	L4	L5	L6
10	6264-06-09-*97	80	26.9	189.6	27	88	142.5	20.5	25	52.5	118.5	182.3	14.4	-	29.5
25	6264-08-13-*97	100	35	193.1	45.5	91.5	146	25	12	37.9	124.5	182.3	14.4	-	36.5
32	6264-10-17-*97	120	41.3	198.6	52	97	151.5	26.5	13.5	45	153	182.3	14.4	-	46.5

NG	ISO-code	d1max	d2max	d3	t3	d4	t4	d5	d6
10	6264-06-09-*97	14.7	4.8	7.5	10	M12	20	13.5	20
25	6264-08-13-*97	23.4	6.3	7.5	10	M16	27	17.5	25
32	6264-10-17-*97	32	6.3	7.5	10	M18	28	20	30

NG	ISO-code	Bolt kit - DIN912 12.9	Kit		Surface finish
			NBR	FPM	
10	6264-06-09-*97	BK-M12 x 45-4pcs	108 Nm ±15%	SK-RE10RN50	SK-RE10RV50
25	6264-08-13-*97	BK-M16 x 70-4pcs	264 Nm ±15%	SK-RE25RN50	SK-RE25RV50
32	6264-10-17-*97	BK-M18 x 75-4pcs	398 Nm ±15%	SK-RE32RN50	SK-RE32RV50

RET_R4V-R6V_UK.INDD CM

RE*M*T/R4V

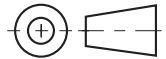
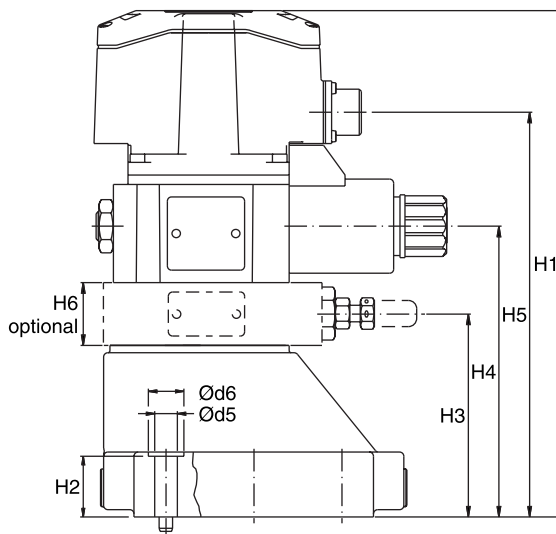
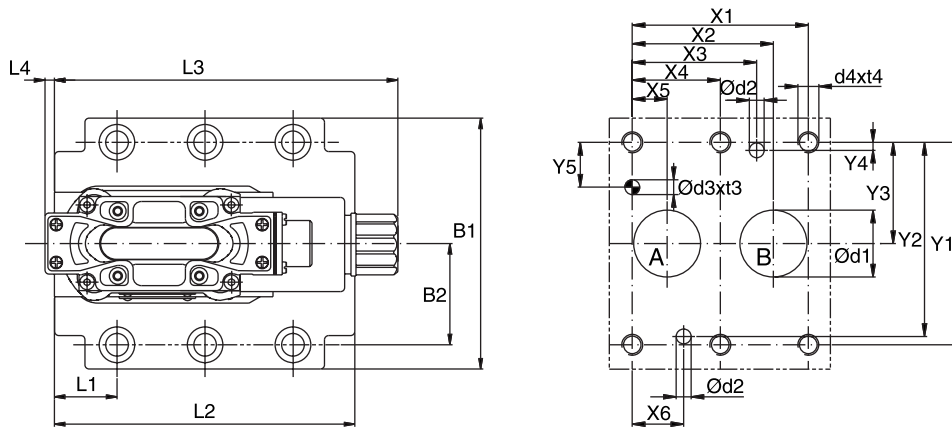



NG	ISO-code	x1	x2	x3	x4	x5	x6	x7	y1	y2	y3	y4	y5	y6
10	6264-06-07-*-97	42.9	35.8	21.5	—	7.2	21.5	0	66.7	58.8	33.4	7.9	14.3	—
25	6264-08-11-*-97	60.3	49.2	39.7	—	11.1	20.6	0	79.4	73	39.7	6.4	15.9	—
32	6264-10-15-*-97	84.2	67.5	59.5	42.1	16.7	24.6	0	96.8	92.8	48.4	3.8	21.4	—

Tolerance at X and Y pin holes and screw holes ±0.1, at port holes ±0.2.

NG	ISO-code	B1	B2	H1	H2	H3	H4	H5	H6	L1	L2	L3	L4	L5	L6
10	6264-06-07-*-97	87.3	33.35	204.8	21	60	102	156.5	30	28.3	94.1	164.2	4.5	—	—
25	6264-08-11-*-97	105	39.7	231.3	29	86.5	128.5	183	30	34	126.1	164.2	4.5	—	—
32	6264-10-15-*-97	120	48.4	241.8	29	97	139	193.5	30	29.9	143.6	164.2	4.5	—	—

NG	ISO-code	d1max	d2max	d3	t3	d4	t4	d5	d6
10	6264-06-07-*-97	15	7	7.1	8	M10	16	10.8	17
25	6264-08-11-*-97	23.4	7.1	7.1	8	M10	18	10.8	17
32	6264-10-15-*-97	32	7.1	7.1	8	M10	20	10.8	17

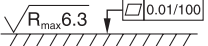
NG	ISO-code	Bolt kit -  DIN912 12.9		Kit 		Surface finish 
				NBR	FPM	
10	6264-06-07-*-97	BK-M10 x 35-4pcs	63 Nm ±15%	SK-RE10MN50	SK-RE10MV50	
25	6264-08-11-*-97	BK-M10 x 45-4pcs	63 Nm ±15%	SK-RE25MN50	SK-RE25MV50	
32	6264-10-15-*-97	BK-M10 x 45-6pcs	63 Nm ±15%	SK-RE32MN50	SK-RE32MV50	

RET_R4V-R6V_UK.INDD CM



Pilot operated relief valve with proportional adjustment. Series VBY*K is a pilot operated pressure valve with external drain. The external drain allows an application as sequence and as pressure relief valve. For use as pressure relief valve observe hydraulic connection.

The optimum performance can be achieved in combination with the digital amplifier module PCD00A-400.

Features

- Proportional adjustment
- Subplate mounting acc. to ISO 5781
- External drain
- Main stage spool type valve
- Pilot stage seated type valve



VBY*K06



VBY*K10

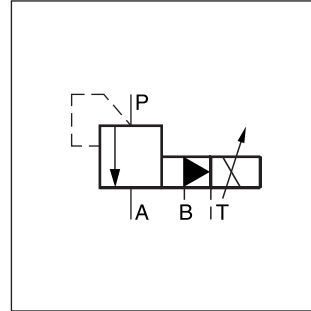

VBY*K06

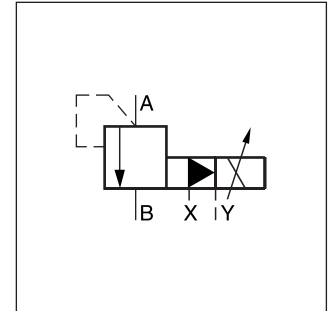

VBY*K10

VBY*K06

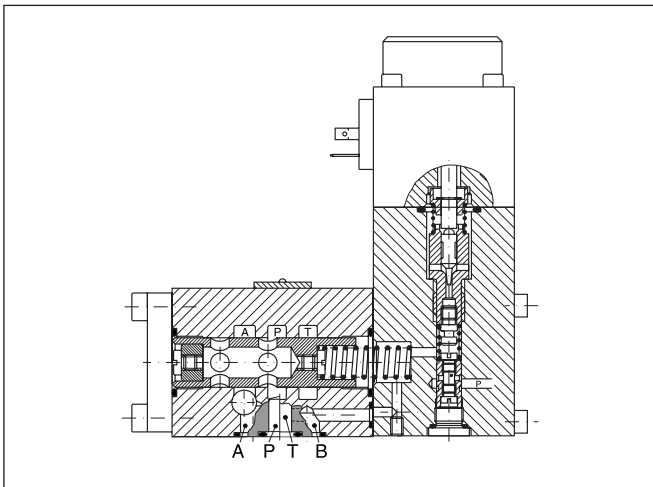

VBY*K10

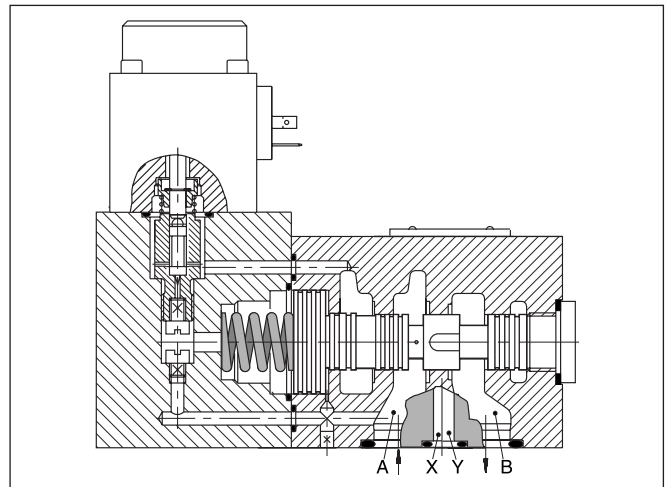

Ordering code

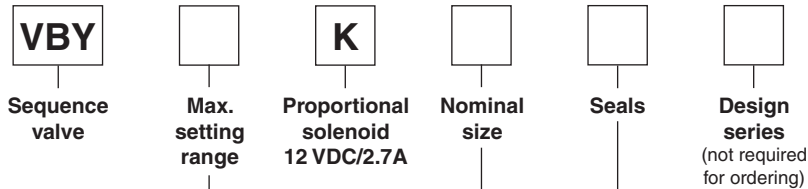

Code	Max. setting range
064	64 bar
100	100 bar
160	160 bar
210	210 bar
315	315 bar

**Bold letters =
Short-term availability**

Code	Seals
N	NBR
V	FPM

Code	Nominal size
06	NG06
10	NG10

VBK_UK.INDD CM



Technical Data / Characteristic Curves

Technical data

General			Proportional pressure valve	
Design	Proportional pressure valve			
Nominal size	NG06		NG10	
Interface	Subplate mounting according to ISO 5781			
Actuation	Proportional solenoid			
Mounting position	unrestricted			
Ambient temperature	[°C]	-20 ... +70		
Weight	[kg]	5		
Hydraulics				
Max. operating pressure	[bar]	Ports P and A 315; Port T depressurized	Ports A and B 315; Port Y depressurized	
Nominal flow	[l/min]	40	160	
Adjustment range	[bar]	up to 64, 100, 160, 210, 315		
Fluid	Hydraulic oil as per DIN 51 524 ... 525			
Viscosity	recommended	[cSt] / [mm²/s]	30 ... 50	
	maximum	[cSt] / [mm²/s]	20 ... 380	
Pressure medium temperature	recommended	[°C]	30 ... 50	
	maximum	[°C]	-20 ... +70	
Permitted contamination	ISO 4406 (1999); 18/16/13			
Linearity	[%]	±3.5 at > 15% prom.		
Repeatability	[%]	<±2		
Hysteresis	[%]	±1.5 to pmax		
Response time	[ms]	<150	<200	
Manufacturing tolerance	[%]	±5 to pmax		
Electrical				
Duty ratio	[%]	100 ED		
Protection class		IP65 at EN 60529 (plugged and mounted)		
Nominal voltage	[VDC]	12		
Max. current	[A]	2.7		
Ambient temperature	[°C]	-20...+70		
Coil resistance	[Ohm]	21 at 20°C		
Solenoid connection		Connector as per EN 175301-803		
Power amplifier		PCD00A-400		

4

Characteristic pressure curves for NG06 $p = f(U_{set})$

Setting range max. 64 bar

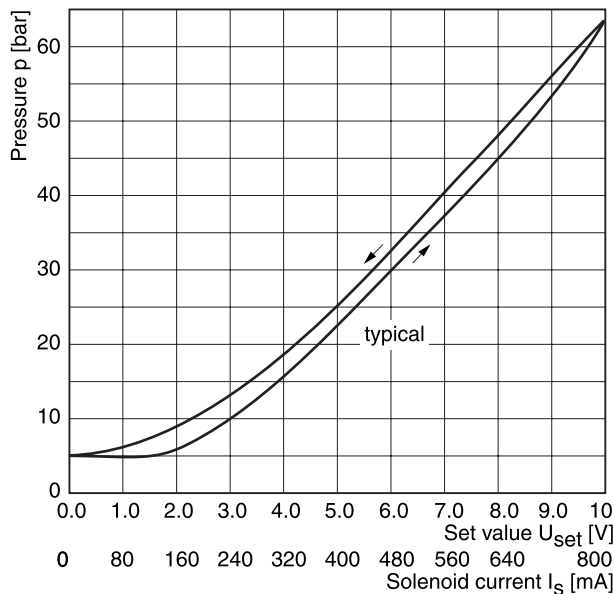

Setting range max. 210 bar

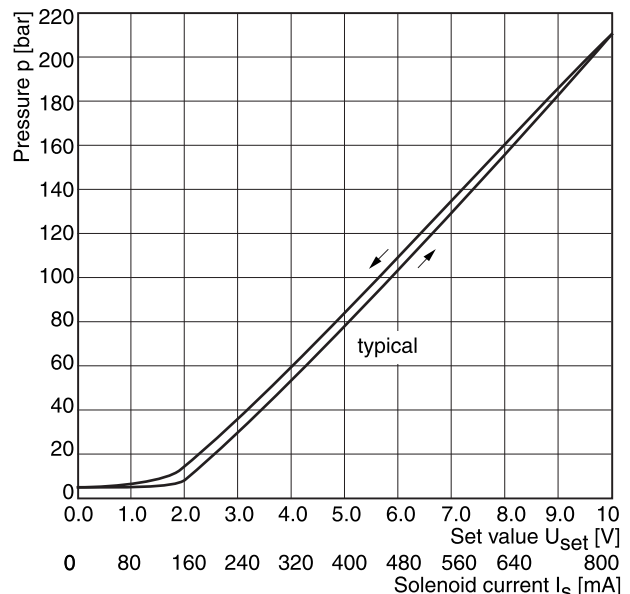

VBYK_UK.INDD CM



p/Q characteristics

measured at $t = 50^{\circ}\text{C}$ and $v = 35 \text{ mm}^2/\text{s}$

NG06

Setting range max. 64 bar

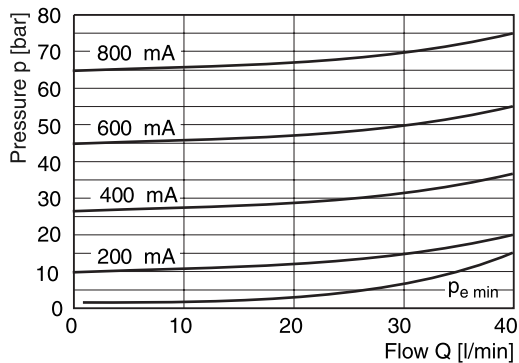

Setting range max. 100 bar

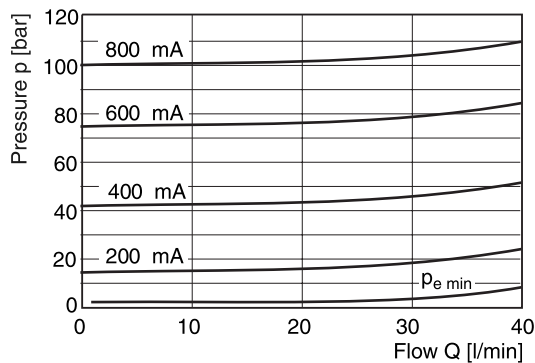

Setting range max. 160 bar

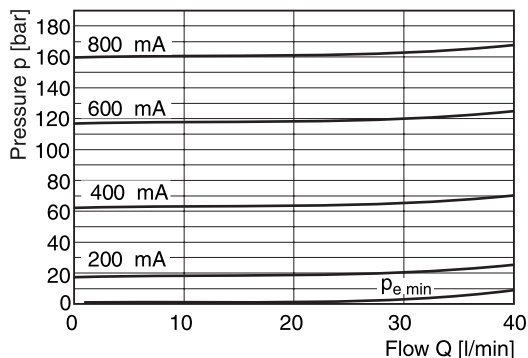

Setting range max. 210 bar

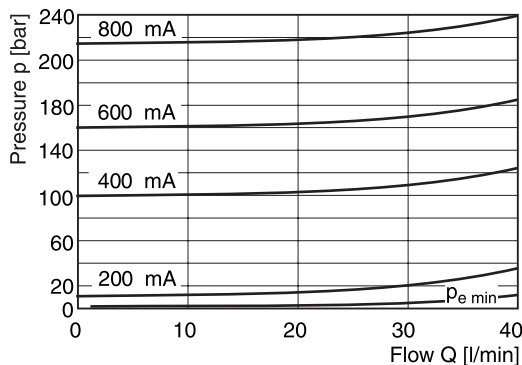

Setting range max. 315 bar

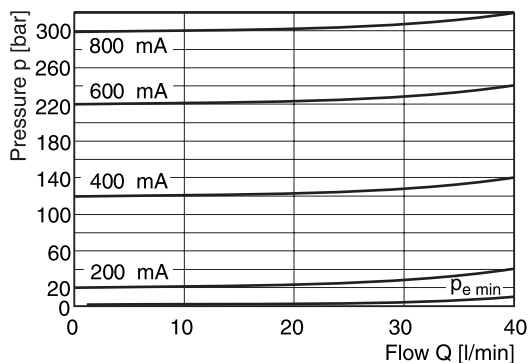

4

Step response signal

NG06

Setting range max. 210 bar

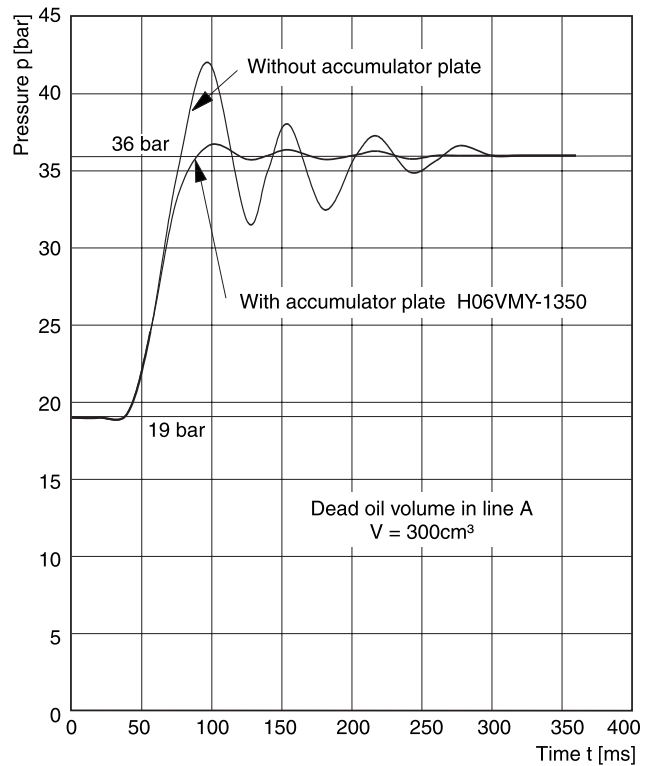
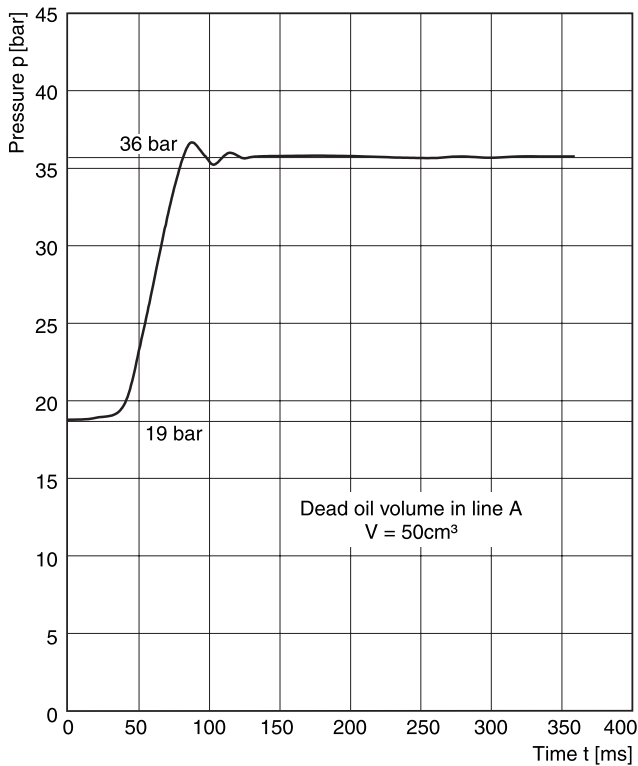

p/Q characteristics

measured at $t = 50^\circ\text{C}$ and $v = 35 \text{ mm}^2/\text{s}$

NG10

Setting range max. 64 bar

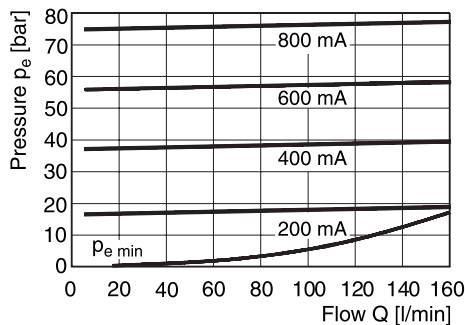

Setting range max. 100 bar

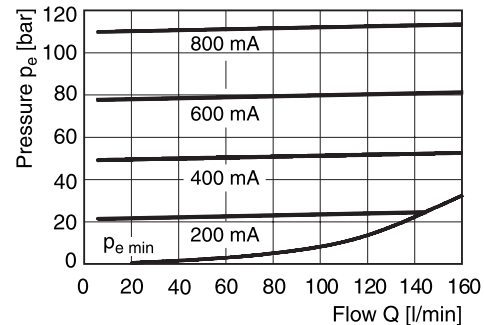

Setting range max. 160 bar

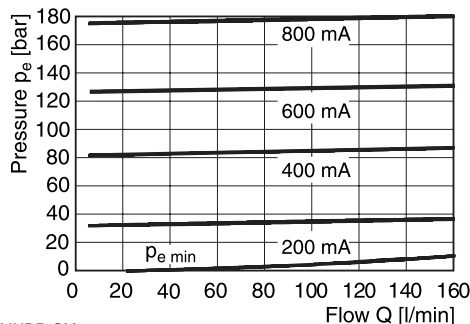

Setting range max. 210 bar

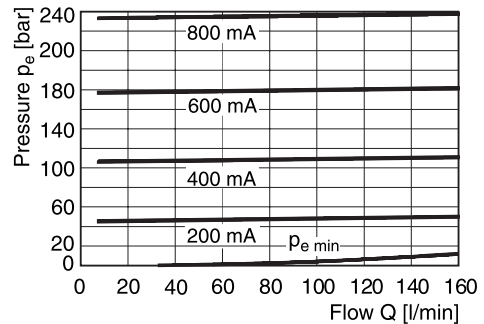

VBYK_UK.INDD CM

NG06

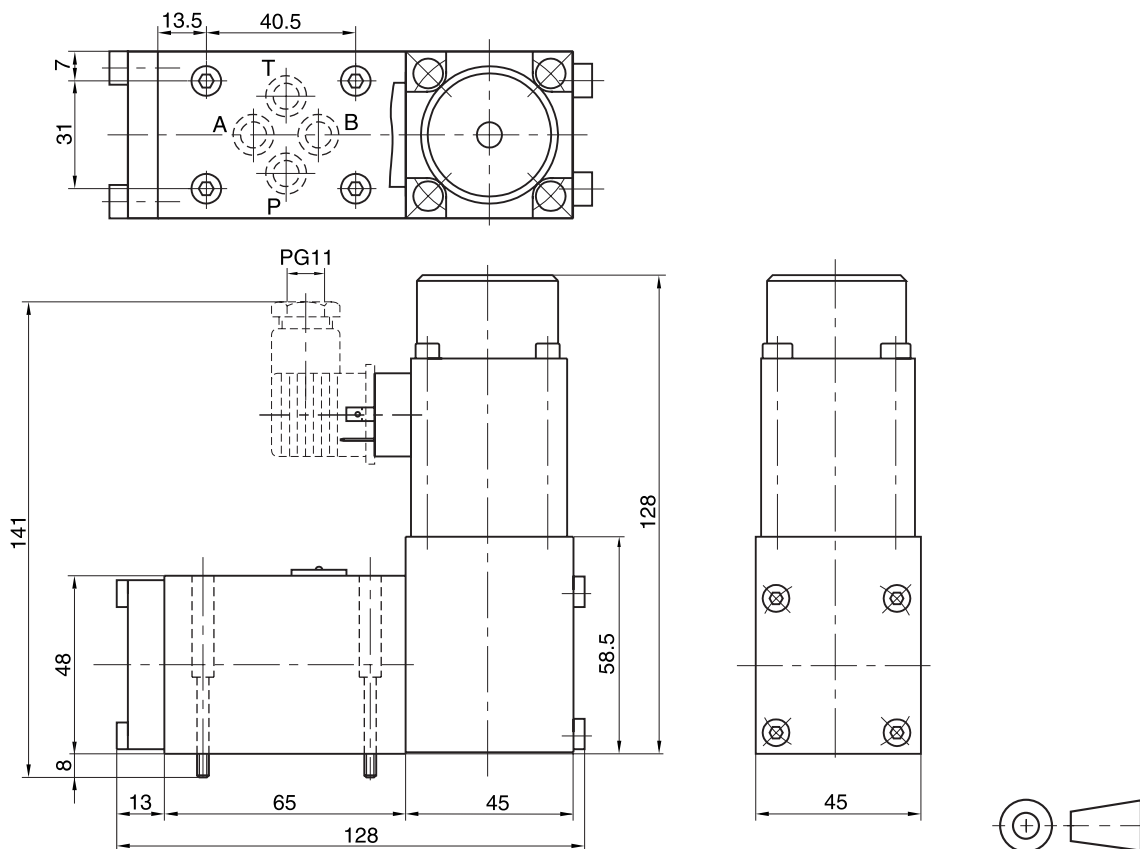

4

Surface finish	Bolt kit - DIN 912 12.9		Kit	
	BK-M5x30-4pcs	7.6 Nm ±15%	NBR	FPM
			SK-VMY-L06-N	SK-VMY-L06-V

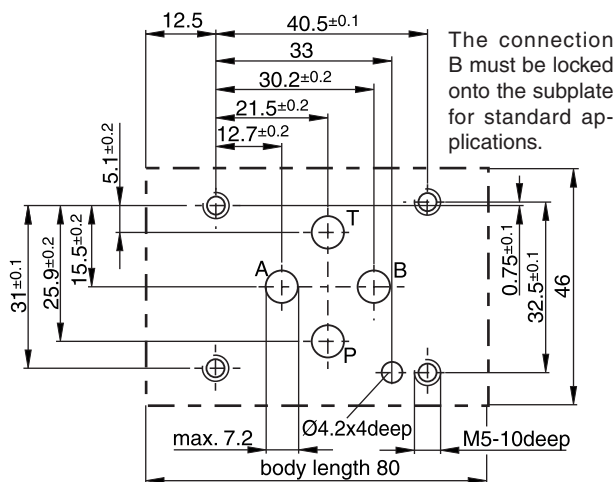

Mounting pattern ISO 5781-03-04-0-00

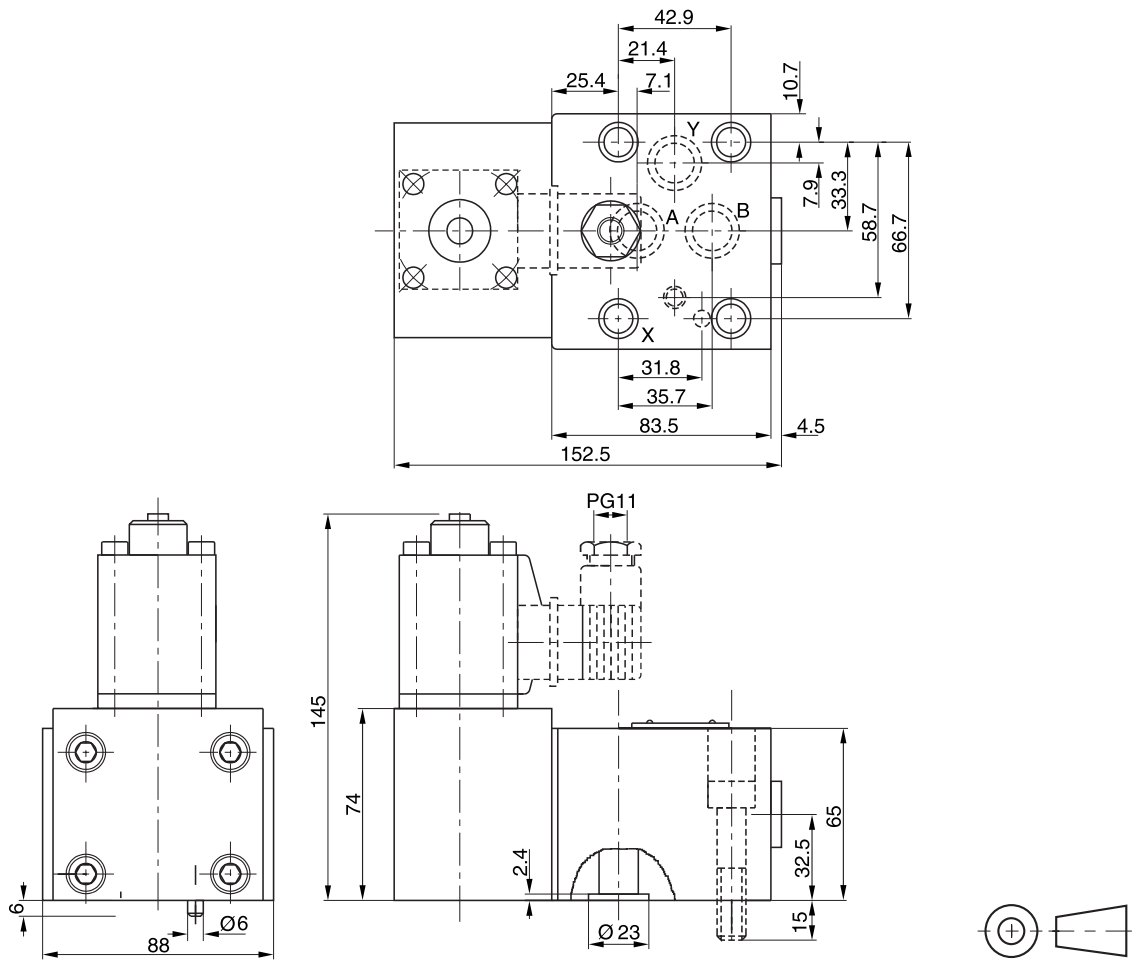

NG10

4

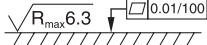

Surface finish	Bolt kit -  DIN 912 12.9		 Kit FPM
	BK-M10x50-4pcs	63 Nm ±15%	SK-VB/VM-A10V

Mounting pattern ISO 5781-06-07-0-00

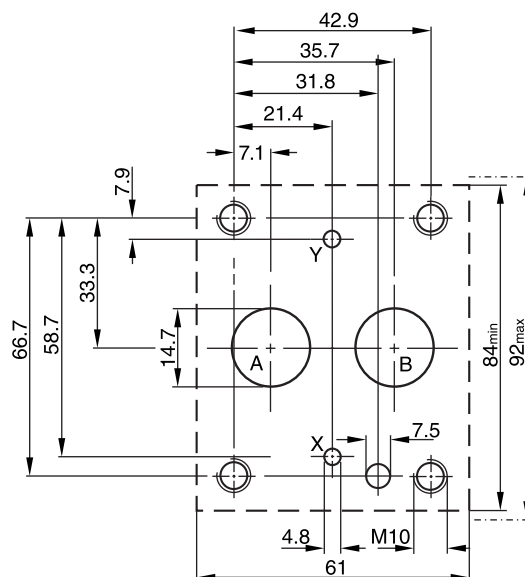

Characteristics

Subplate mounted unloading valves are available with both Parker (series UR/US) and Denison (series R4U) model codes.

These valves are used to unload a circuit at low pressure. The mechanically adjustable pressure signal to unload the main stage has to be applied to port X. The pressure differential between opening and closing is nominal 15 or 28 % of the setting pressure.

28 % for pressure stages bar 70, 175

15 % for pressure stages bar 250, 350

Typical applications are unloading of pumps in an accumulator circuit or unloading of the low pressure stage of a double pump.

In addition, the US series is vented by electrical operation.

Features

- Pilot operated unloading valve
- Interface
 - subplate mounting to ISO 5781
- 4 pressure stages
- 2 switching types (series US)
- 3 adjustment modes
 - hand knob
 - acorn nut with lead seal
 - DIN lock

**Unloading Valves
Series UR / US (Parker), R4U (Denison)**

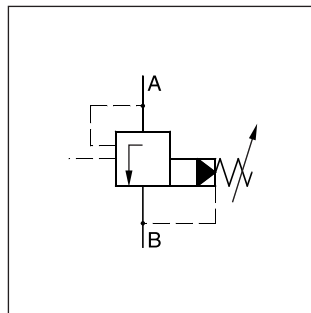

UR

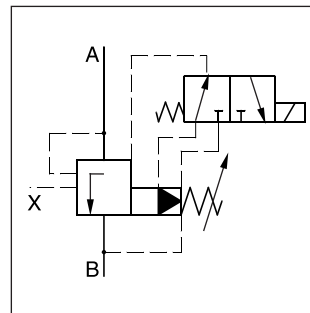

US

4

**UR25M
R4U06**

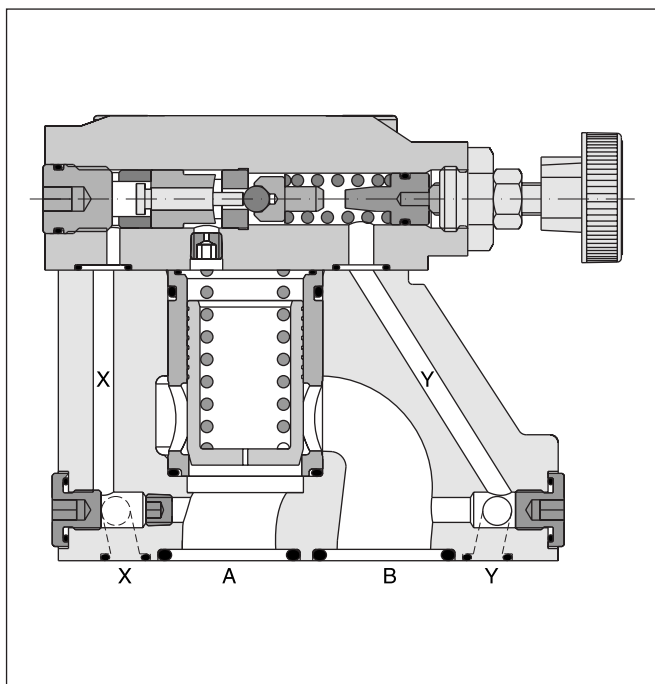

**US25M
R4U06 with vent function**

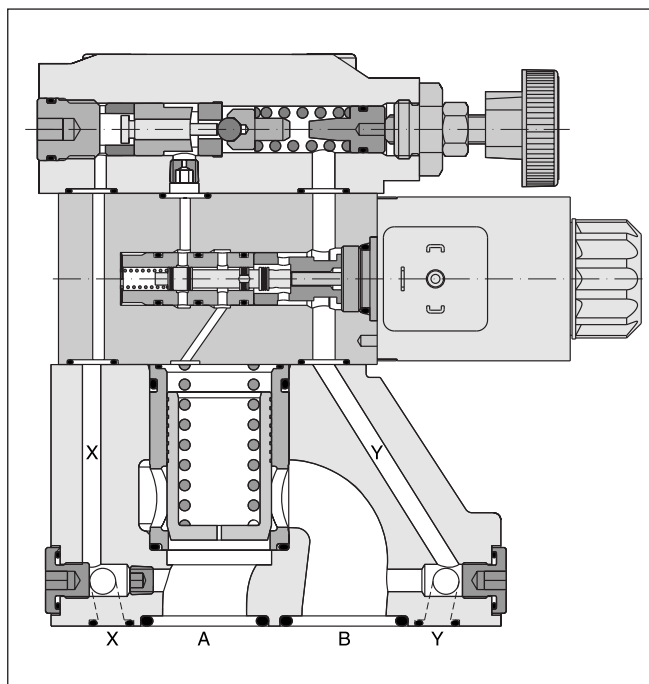

4

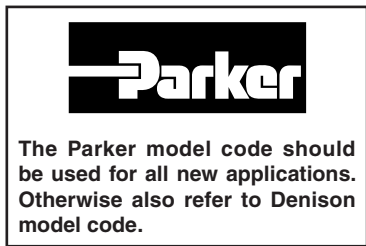
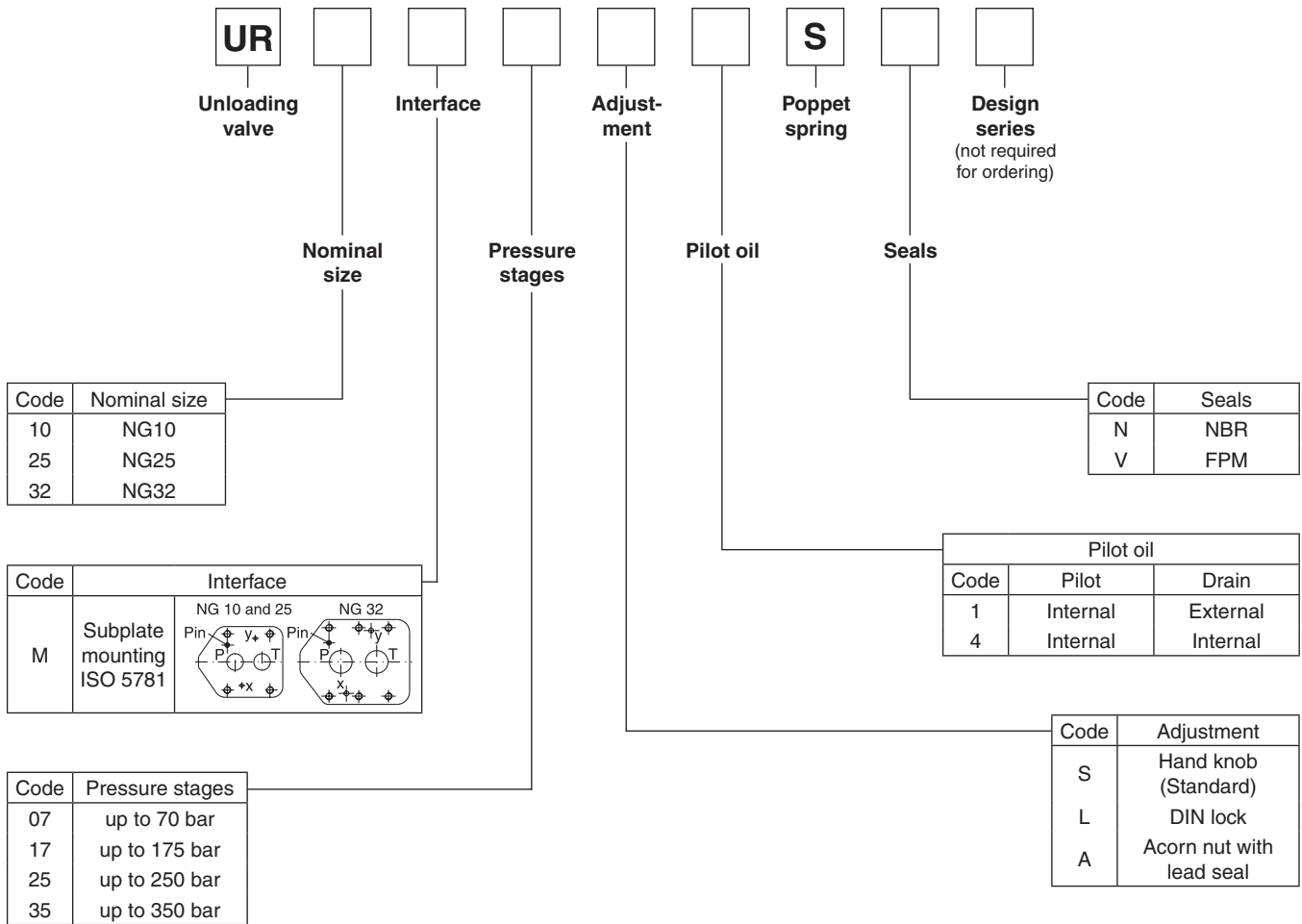

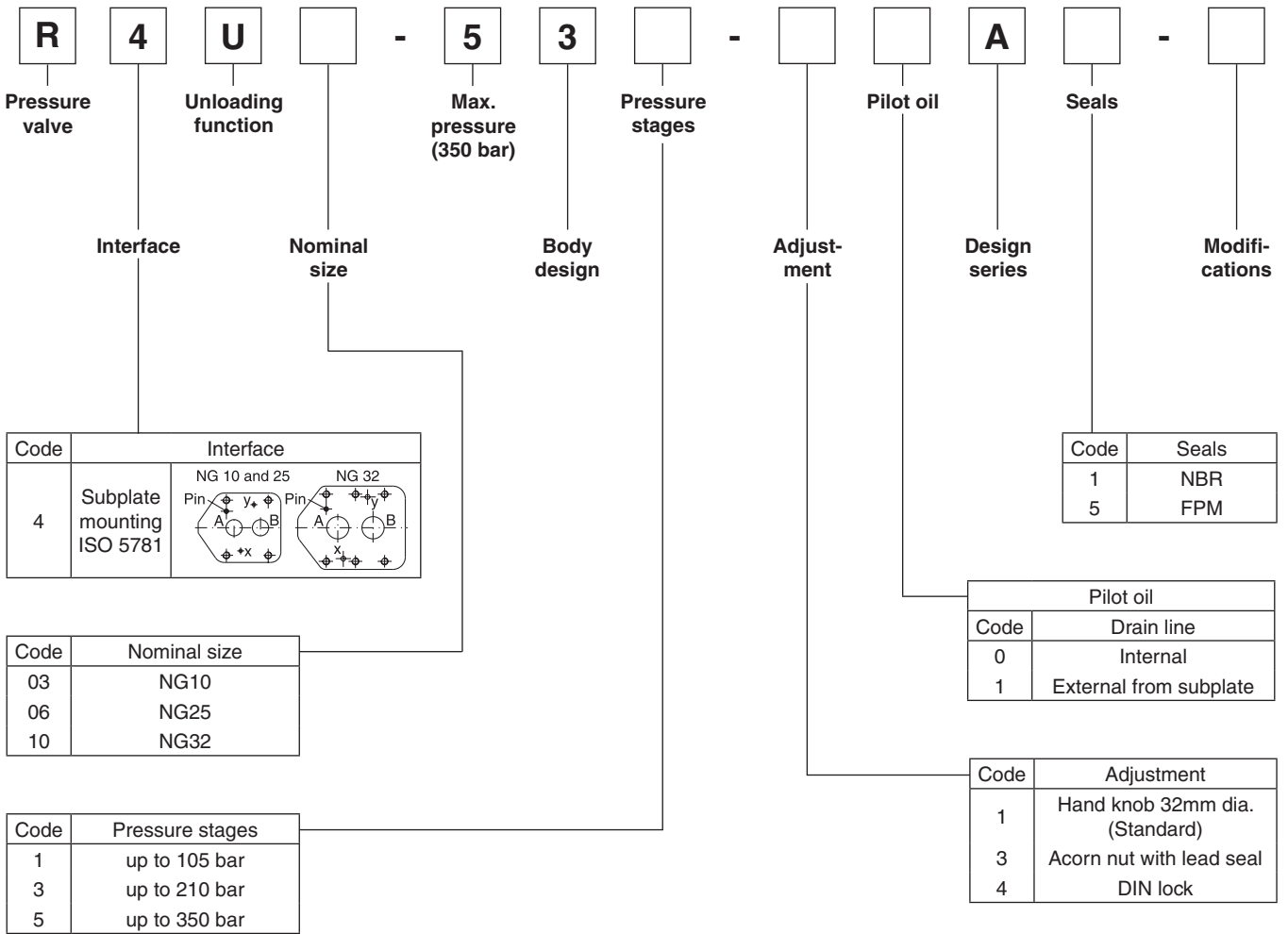

4

DENISON Hydraulics

The Denison model code is available for existing applications. Otherwise also refer to Parker model code.

4

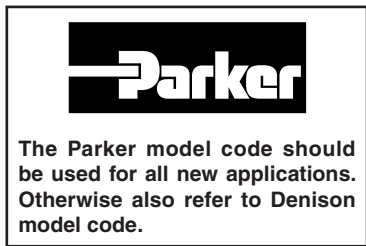
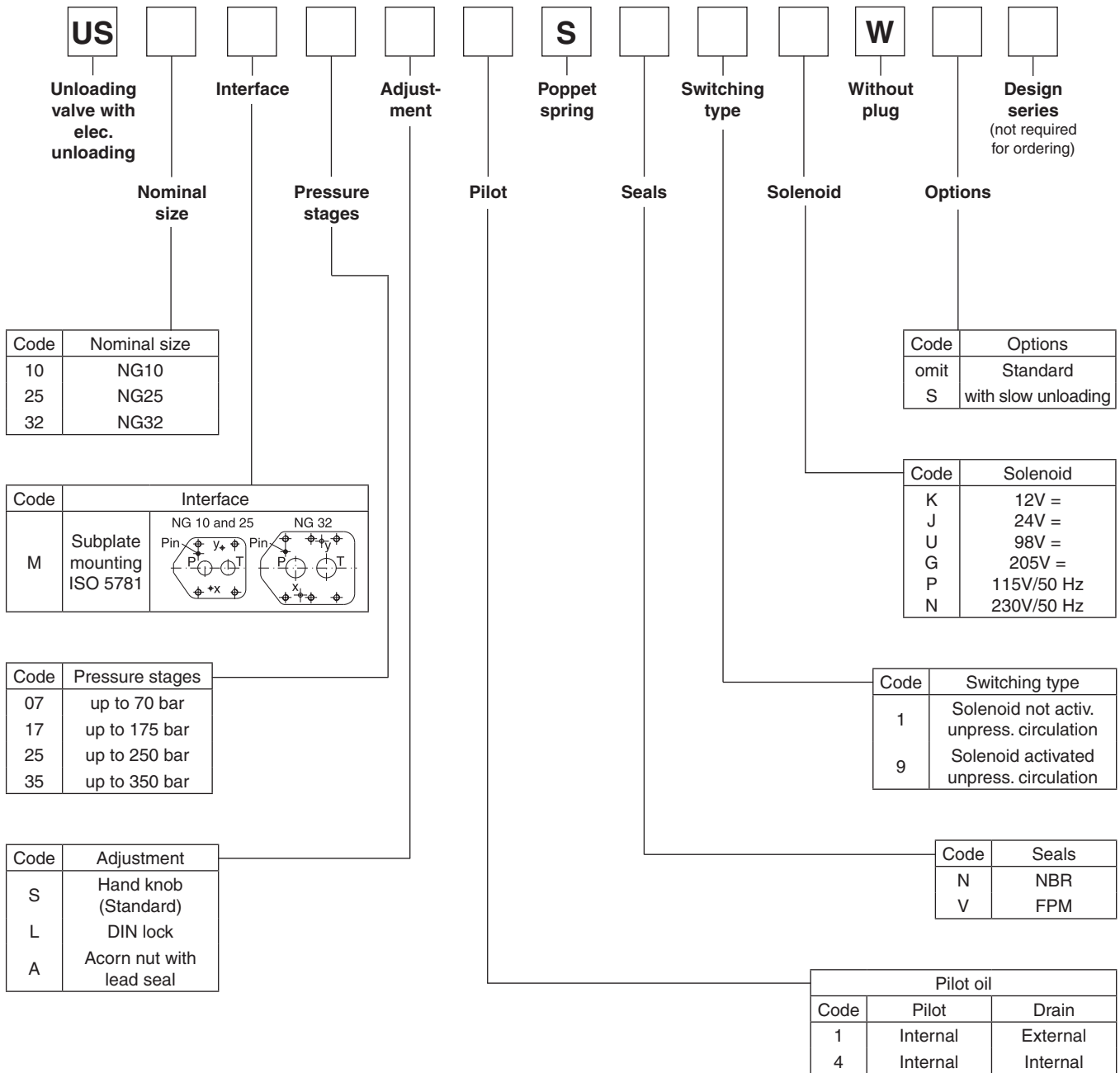

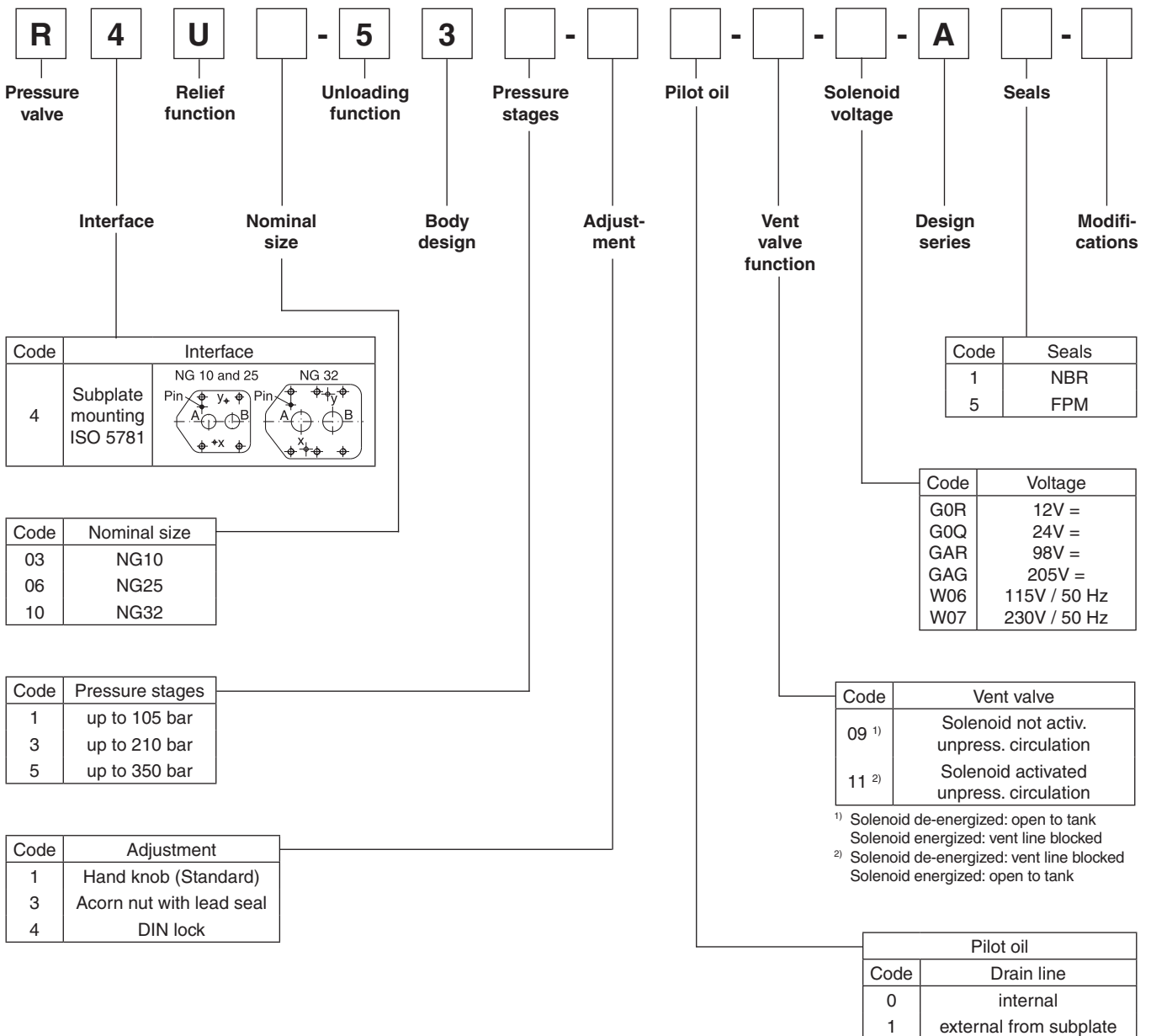

4

DENISON Hydraulics

The Denison model code is available for existing applications. Otherwise also refer to Parker model code.

UR / R4U

General				
Nominal size		10	25	32
Interface		Subplate mounting acc. ISO 5781		
Mounting position		as desired, horizontal mounting preferred		
Ambient temperature	[°C]	-20...+80		
Weight	[kg]	2.7	4.5	6.0
Hydraulic				
Max. operating pressure	[bar]	Ports A and X 350, Ports B and Y depressurized		
Pressure stages	[bar]	75, 175, 250, 350		
Pressure differential		28 % (for pressure stages 75 bar and 175 bar); 15% (for pressure stages 250 bar and 350 bar)		
Nominal flow	[l/min]	150	350	650
Fluid		Hydraulic oil according to DIN 51524 ... 525		
Viscosity, recommended	[cSt] / [mm ² /s]	30 ... 50		
	permitted	20...380		
	[mm ² /s]	20 ... 380		
Fluid temperature	[°C]	-20 ... +70		
Filtration		ISO 4406 (1999); 18/16/13		

US / R4U with vent function

General							
Nominal size		10	25	32			
Interface		Subplate mounting acc. ISO 5781					
Mounting position		as desired, horizontal mounting preferred					
Ambient temperature	[°C]	-20...+80					
Weight	[kg]	4.4	6.2	7.7			
Hydraulic							
Max. operating pressure	[bar]	Ports A and X 350, Ports B and Y depressurized					
Pressure stages	[bar]	75, 175, 250, 350					
Pressure differential		28 % (for pressure stages 75 bar and 175 bar); 15% (for pressure stages 250 bar and 350 bar)					
Nominal flow	[l/min]	150	350	650			
Fluid		Hydraulic oil according to DIN 51524 ... 525					
Viscosity, recommended	[cSt] / [mm ² /s]	30 ... 50					
	permitted	20...380					
Fluid temperature	[°C]	-20 ... +70					
Filtration		ISO 4406 (1999); 18/16/13					
Electrical (solenoid)							
Duty ratio	[%]	100 ED; CAUTION: coil temperature up to 180 °C possible					
Max. switching frequency		160000 (DC), 7200 (AC)					
Protection class		IP65 in according with EN 60529 (plugged and mounted)					
Code Denison / Code Parker]	Code	G0R / K	G0Q / J	GAR / U	GAG / G	W06 / P	W07 / N
Supply voltage	[V]	12V =	24V =	98V =	205V =	150 at 50Hz	230 at 50Hz
Tolerance supply voltage	[%]	+5...-10	+5...-10	+5...-10	+5...-10	+5...-10	+5...-10
Power consumption	hold [W]	31	31	31	31	78	78
	in rush [W]	31	31	31	31	264	264
Solenoid connection		Connector as per EN 175301-803					
Wiring min.	[mm ²]	3 x 1.5 recommended					
Wiring length max.	[m]	50 recommended					

4

p/Q performance curve

UR/US ¹⁾

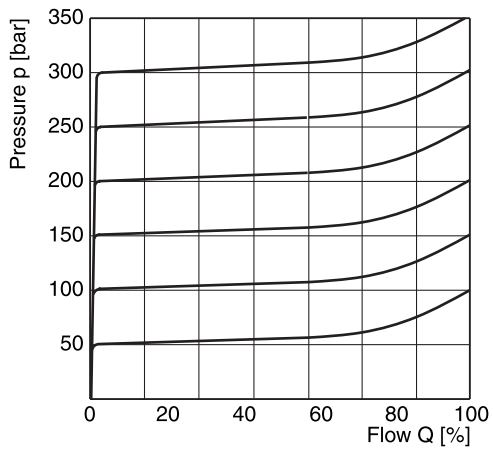

Minimum pressure curve

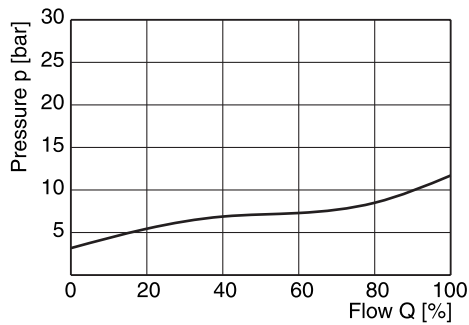

¹⁾ The performance curves are measured with external drain.
 For internal drain the tank pressure has to be added to curve.

UR*M / R4U

4

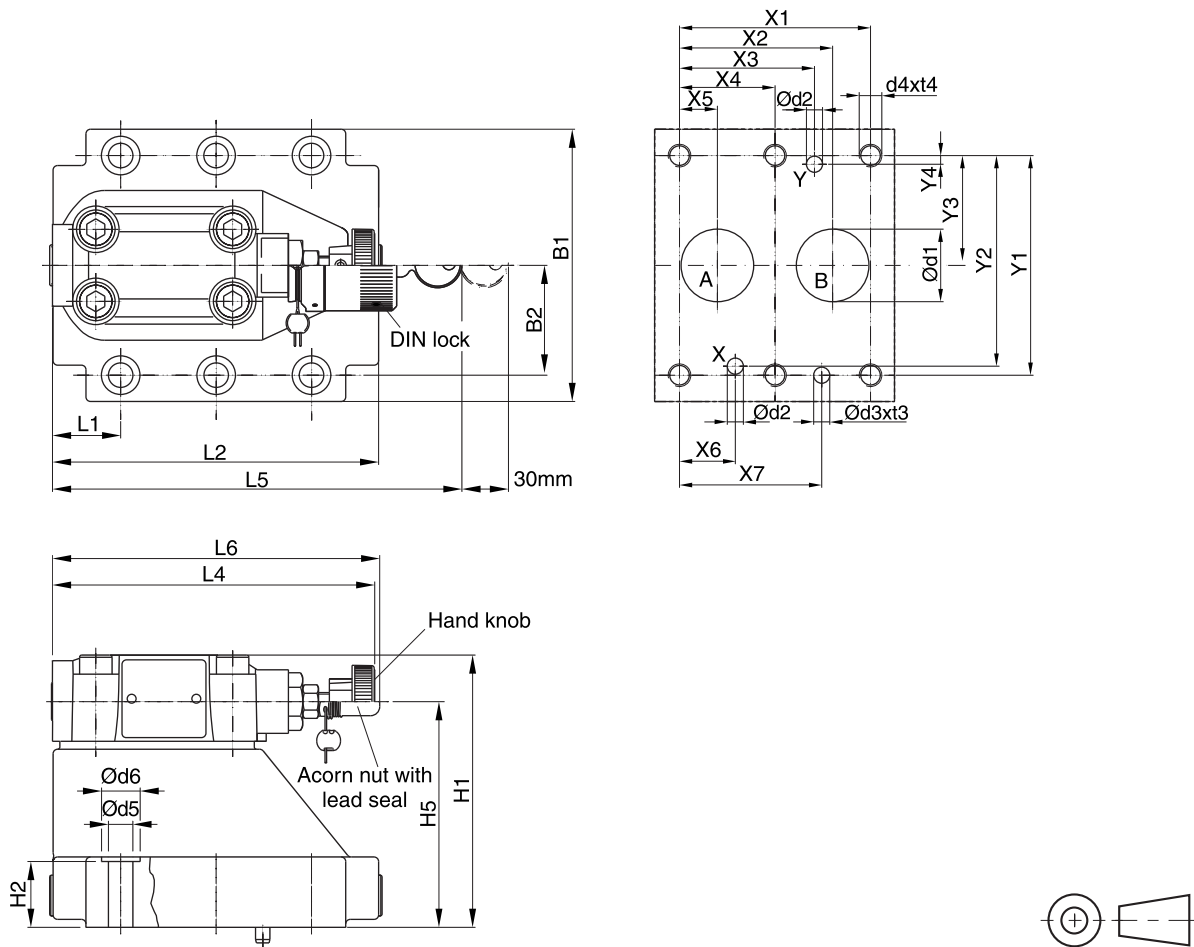

NG	ISO-code	x1	x2	x3	x4	x5	x6	x7	y1	y2	y3	y4	y5	y6
10	5781-06-07-0-00	42.9	35.8	21.5	-	7.2	21.5	31.8	66.7	58.8	33.4	7.9	-	-
25	5781-08-10-0-00	60.3	49.2	39.7	-	11.1	20.6	44.5	79.4	73	39.7	6.4	-	-
32	5781-10-13-0-00	84.2	67.5	59.5	42.1	16.7	24.6	62.7	96.8	92.8	48.4	3.8	-	-

Tolerance at X and Y pin holes and screw holes ±0.1, at port holes ±0.2.

NG	ISO-code	B1	B2	H1	H2	H3	H4	H5	H6	L1	L2	L3	L4	L5	L6
10	5781-06-07-0-00	87.3	33.35	83	21	62.5	-	-	-	29	94.8	-	143	181	144.8
25	5781-08-10-0-00	105	39.7	109.5	29	89	-	-	-	34.7	126.8	-	143	181	144.8
32	5781-10-13-0-00	120	48.4	120	29	99.5	-	-	-	30.6	144.3	-	143	181	144.8

NG	ISO-code	d1max	d2max	d3	t3	d4	t4	d5	d6
10	5781-06-07-0-00	15	7	7.1	8	M10	16	10.8	17
25	5781-08-10-0-00	23.4	7.1	7.1	8	M10	18	10.8	17
32	5781-10-13-0-00	32	7.1	7.1	8	M10	20	10.8	17

NG	ISO-code	Bolt kit - DIN912 12.9	Kit		Surface finish	
			NBR	FPM		
10	5781-06-07-0-00	BK-M10 x 35-4pcs	63 Nm ±15%	SK-UR10MN50	SK-UR10MV50	
25	5781-08-10-0-00	BK-M10 x 45-4pcs	63 Nm ±15%	SK-UR25MN50	SK-UR25MV50	
32	5781-10-13-0-00	BK-M10 x 45-6pcs	63 Nm ±15%	SK-UR32MN50	SK-UR32MV50	

UR-US-R4U_UK.INDD CM

**US*M / R4U
with vent function**

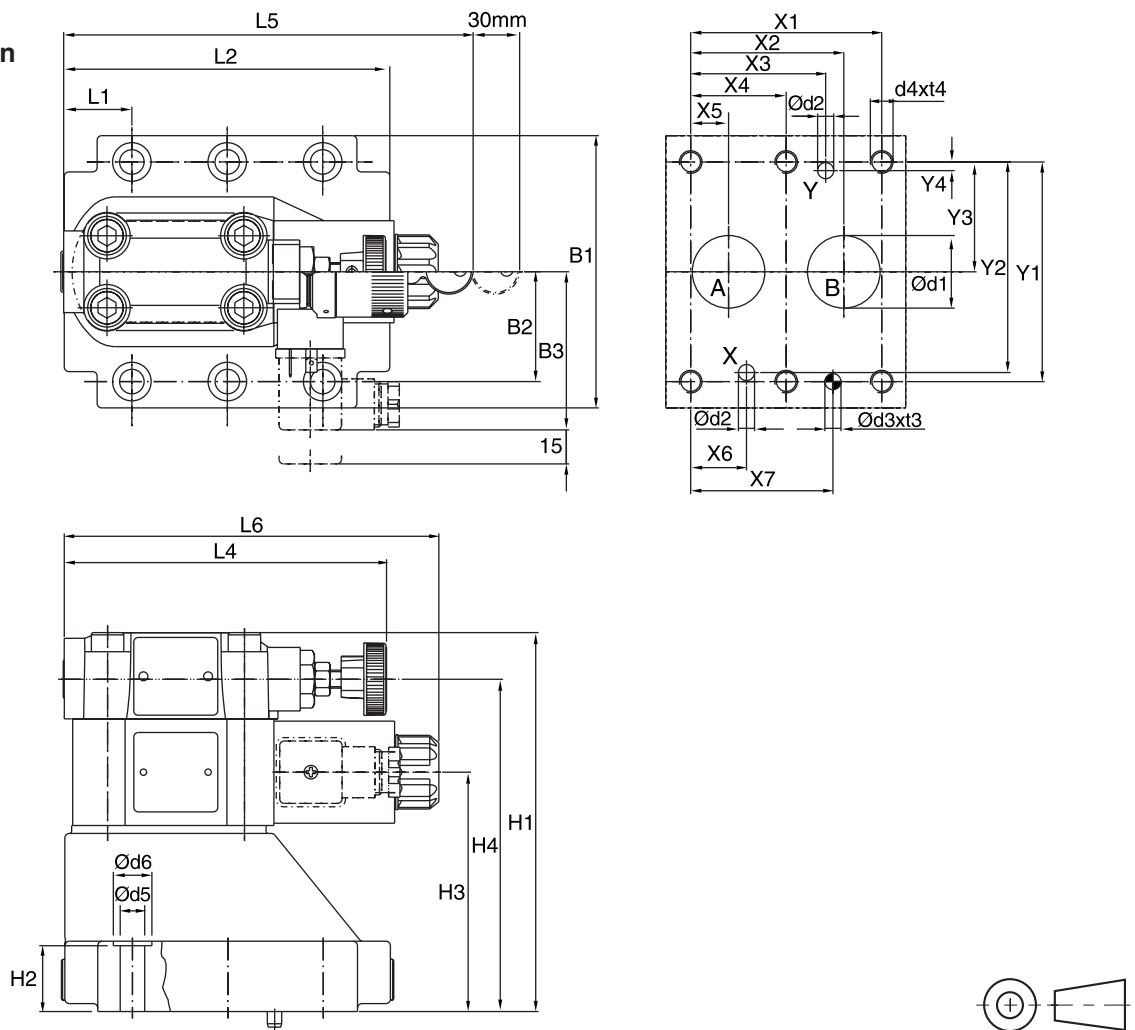

4

NG	ISO-code	x1	x2	x3	x4	x5	x6	x7	y1	y2	y3	y4	y5	y6
10	5781-06-07-0-00	42.9	35.8	21.5	-	7.2	21.5	31.8	66.7	58.8	33.4	7.9	-	-
25	5781-08-10-0-00	60.3	49.2	39.7	-	11.1	20.6	44.5	79.4	73	39.7	6.4	-	-
32	5781-10-13-0-00	84.2	67.5	59.5	42.1	16.7	24.6	62.7	96.8	92.8	48.4	3.8	-	-

Tolerance at X and Y pin holes and screw holes ±0.1, at port holes ±0.2.

NG	ISO-code	B1	B2	B3	H1	H2	H3	H4	H5	H6	L1	L2	L3	L4	L5	L6
10	5781-06-07-0-00	87.3	33.35	70	130	21	68.5	109.5	-	-	29	94.8	-	143	181	165.6
25	5781-08-10-0-00	105	39.7	70	156.5	29	95	136	-	-	34.7	126.8	-	143	181	165.6
32	5781-10-13-0-00	120	48.4	70	167	29	105.5	146.5	-	-	30.6	144.3	-	143	181	165.6

NG	ISO-code	d1max	d2max	d3	t3	d4	t4	d5	d6
10	5781-06-07-0-00	15	7	7.1	8	M10	16	10.8	17
25	5781-08-10-0-00	23.4	7.1	7.1	8	M10	18	10.8	17
32	5781-10-13-0-00	32	7.1	7.1	8	M10	20	10.8	17

NG	ISO-code	Bolt kit - DIN912 12.9	Kit		Surface finish
			NBR	FPM	
10	5781-06-07-0-00	BK-M10 x 35-4pcs	63 Nm ±15%	SK-RS10RN50	SK-RS10RV50
25	5781-08-10-0-00	BK-M10 x 45-4pcs	63 Nm ±15%	SK-RS25RN50	SK-RS25RV50
32	5781-10-13-0-00	BK-M10 x 45-6pcs	63 Nm ±15%	SK-RS32RN50	SK-RS32RV50

UR-US-R4U_UK.INDD CM



Subplate mounted sequence valves are available with both Parker (series S) and Denison (series R4S) model codes.

These valves enable a hydraulic system to operate in a pressure sequence. When the system pressure reaches the setting pressure the valve opens and permits flow to the secondary sub-system.

Features

- Pilot operated sequence valve
- Subplate mounting acc. to ISO 5781
- 4 pressure stages
- 3 adjustment modes
 - hand knob
 - acorn nut with lead seal
 - DIN knob

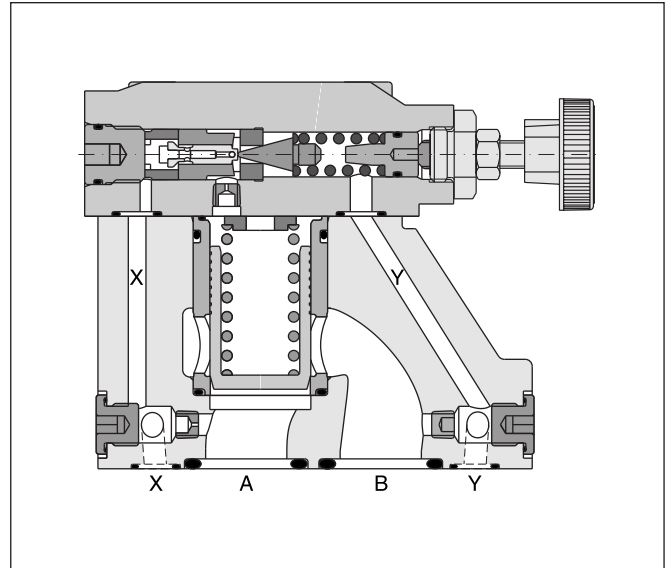
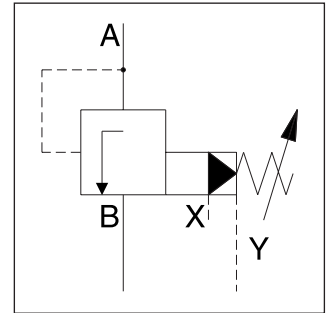

4

Technical data S/R4S

General		10	25	32
Nominal size				
Interface		Subplate mounting acc. ISO 5781		
Mounting position		as desired, horizontal mounting preferred		
Ambient temperature	[°C]	-20...+80		
Weight Series S/R4S	[kg]	2.7	4.5	6.0
Hydraulic				
Max. operating pressure	[bar]	Ports A, B and X 350, port Y depressurized		
Pressure stages	[bar]	75, 175, 250, 350 (series S), 105, 210, 350 (series R4S)		
Nominal flow	[l/min]	150	350	650
Fluid		Hydraulic oil according to DIN 51524 ... 525		
Viscosity, recommended permitted	[cSt] / [mm²/s]	30 ... 50		
	[cSt] / [mm²/s]	20 ... 380		
Fluid temperature	[°C]	-20 ... +70		
Filtration		ISO 4406 (1999); 18/16/13		

Parker

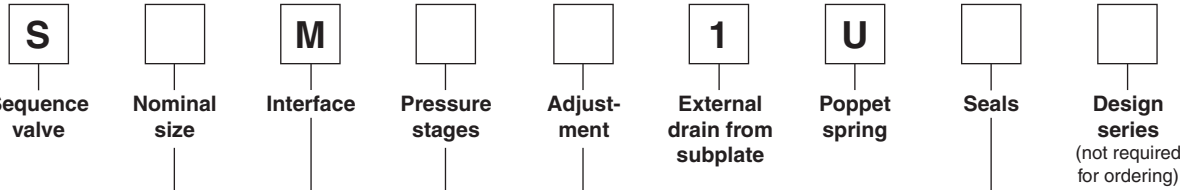

Code	Nominal size
10	NG10
25	NG25
32	NG32

Code	Seals
N	NBR
V	FPM

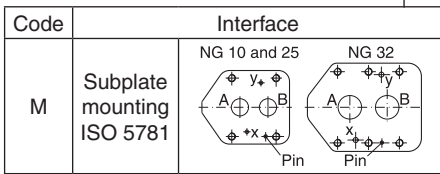

Code	Adjustment
S	Hand knob (Standard)
L	DIN lock
A	Acorn nut with lead seal

Code	Pressure stages
07	up to 70 bar
17	up to 175 bar
25	up to 250 bar
35	up to 350 bar



The Parker model code should be used for all new applications. Otherwise also refer to Denison model code.

Denison

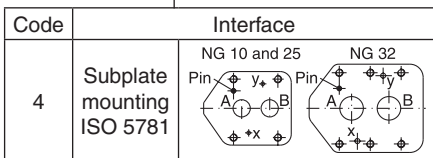
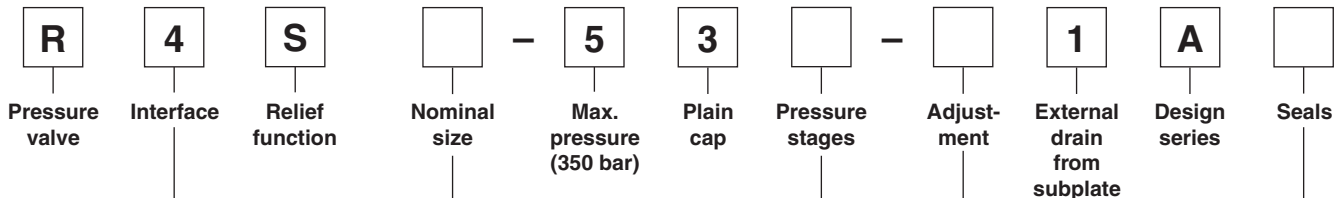

Code	Seals
1	NBR
5	FPM

Code	Nominal size
03	NG10
06	NG25
10	NG32

Code	Adjustment
1	Hand knob 32mm dia. (Standard)
3	Acorn nut with lead seal
4	Adjusting device with key lock

Code	Pressure stages
1	up to 105 bar
3	up to 210 bar
5	up to 350 bar



The Denison model code is available for existing applications. Otherwise also refer to Parker model code.

4

Typical pressure characteristics at closing point

P1 = setting pressure

P2 = operating pressure

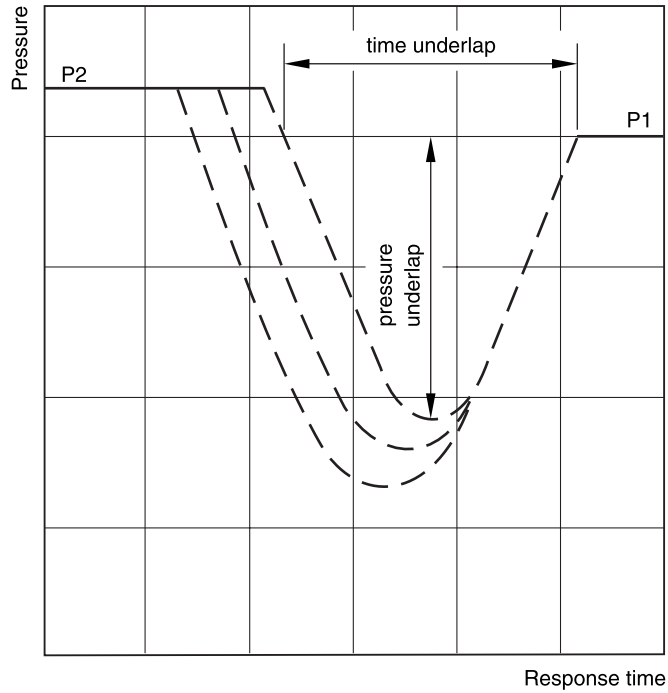

Time and pressure underlap depend on the characteristics of the specific system.

S*M

4

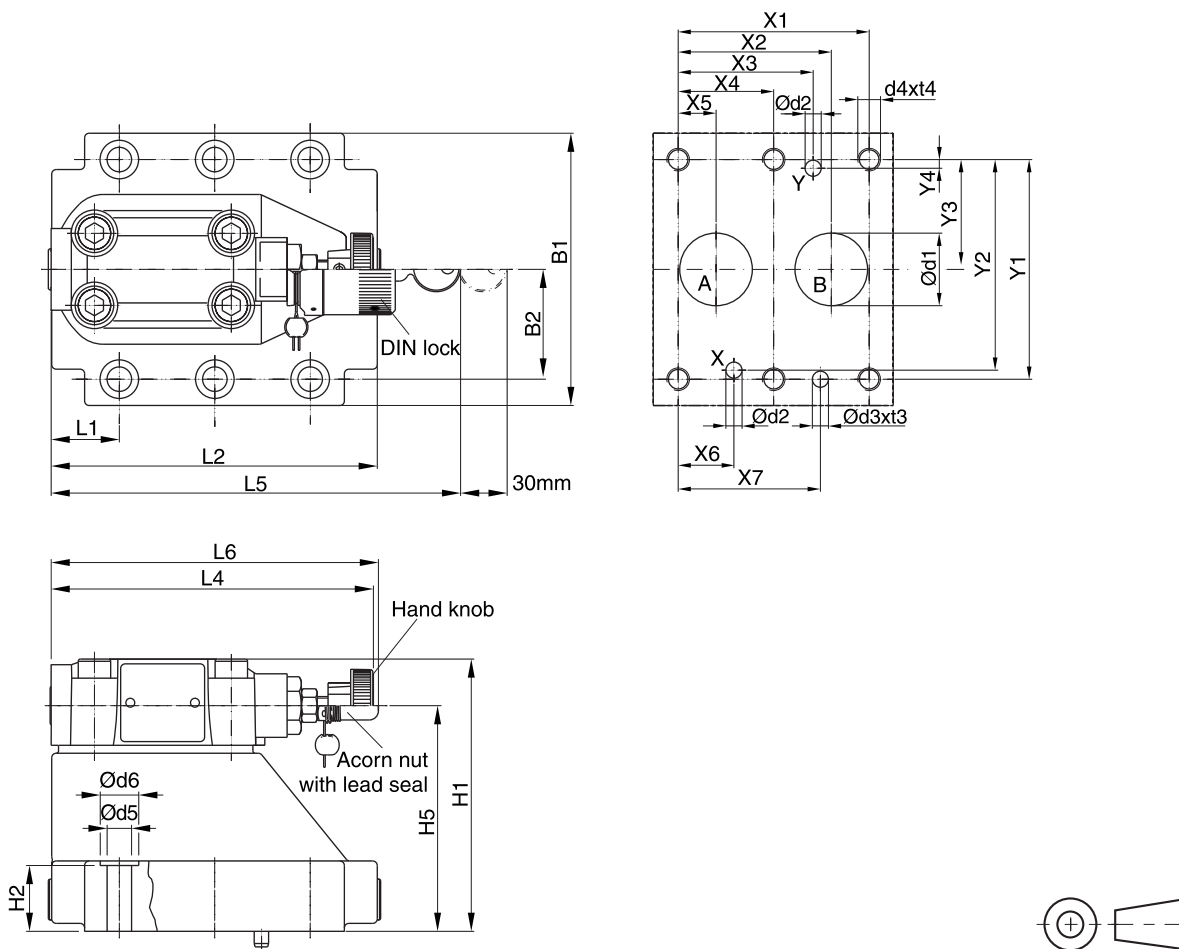

NG	ISO-code	x1	x2	x3	x4	x5	x6	x7	y1	y2	y3	y4	y5	y6
10	5781-06-07-0-00	42.9	35.8	21.5	-	7.2	21.5	31.8	66.7	58.8	33.4	7.9	-	-
25	5781-08-10-0-00	60.3	49.2	39.7	-	11.1	20.6	44.5	79.4	73	39.7	6.4	-	-
32	5781-10-13-0-00	84.2	67.5	59.5	42.1	16.7	24.6	62.7	96.8	92.8	48.4	3.8	-	-

Tolerance at X and Y pin holes and screw holes ±0.1, at port holes ±0.2.

NG	ISO-code	B1	B2	H1	H2	H3	H4	H5	H6	L1	L2	L3	L4	L5	L6
10	5781-06-07-0-00	87.3	33.35	83	21	62.5	-	-	-	29	94.8	-	143	181	144.8
25	5781-08-10-0-00	105	39.7	109.5	29	89	-	-	-	34.7	126.8	-	143	181	144.8
32	5781-10-13-0-00	120	48.4	120	29	99.5	-	-	-	30.6	144.3	-	143	181	144.8

NG	ISO-code	d1max	d2max	d3	t3	d4	t4	d5	d6
10	5781-06-07-0-00	15	7	7.1	8	M10	16	10.8	17
25	5781-08-10-0-00	23.4	7.1	7.1	8	M10	18	10.8	17
32	5781-10-13-0-00	32	7.1	7.1	8	M10	20	10.8	17

NG	ISO-code	Bolt kit - DIN912 12.9	Kit		Surface finish	
			NBR	FPM		
10	5781-06-07-0-00	BK-M10 x 35-4pcs	63 Nm ±15%	SK-UR10MN50	SK-UR10MV50	$\sqrt{R_{max}6.3}$
25	5781-08-10-0-00	BK-M10 x 45-4pcs	63 Nm ±15%	SK-UR25MN50	SK-UR25MV50	
32	5781-10-13-0-00	BK-M10 x 45-6pcs	63 Nm ±15%	SK-UR32MN50	SK-UR32MV50	

S-R4S_UK.INDD CM

Direct operated pressure reducing valve with manual adjustment. Series VM is a direct-controlled, spring loaded 3 way pressure reducing valve, that is open in neutral position. The valve closes the connection from P to A (NG06) or B to A (NG10) when the pre-set pressure is exceeded.

If the pressure increases due to an external influence in connection A, the spool moves and opens the connection from A to T (NG06) or A to Y (NG10) until the pre-set pressure is reached.

Features

- Spool type valve
- Subplate mounting acc. to ISO 5781
- 4 pressure stages at NG06
- 3 pressure stages at NG10
- 2 adjustment modes



NG06



NG10

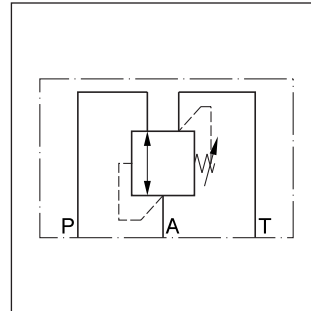

NG06

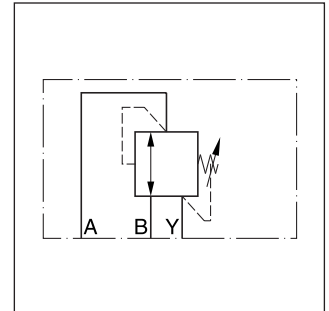

NG10

NG06

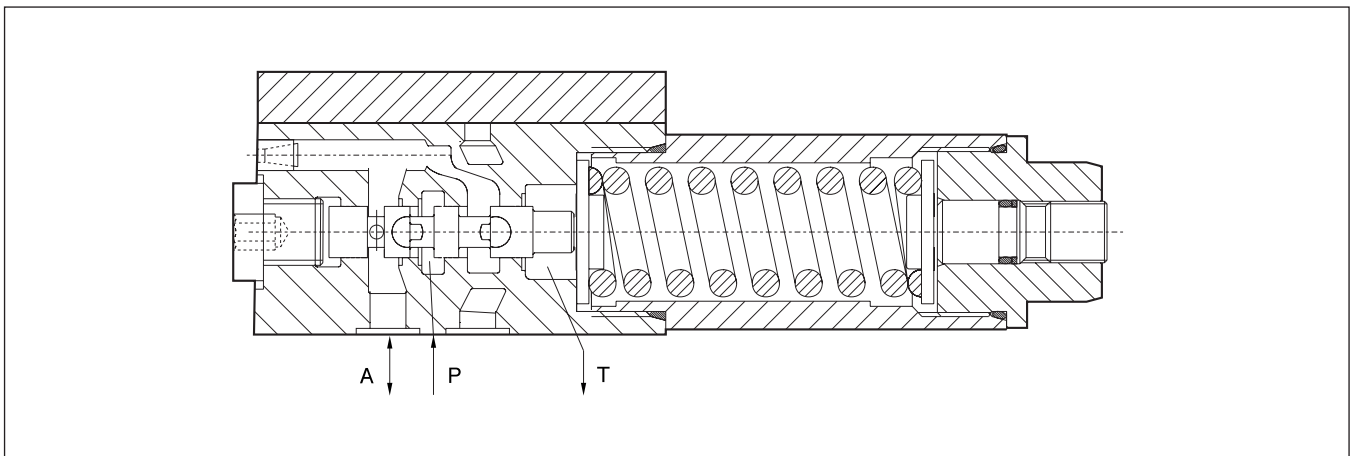

NG10

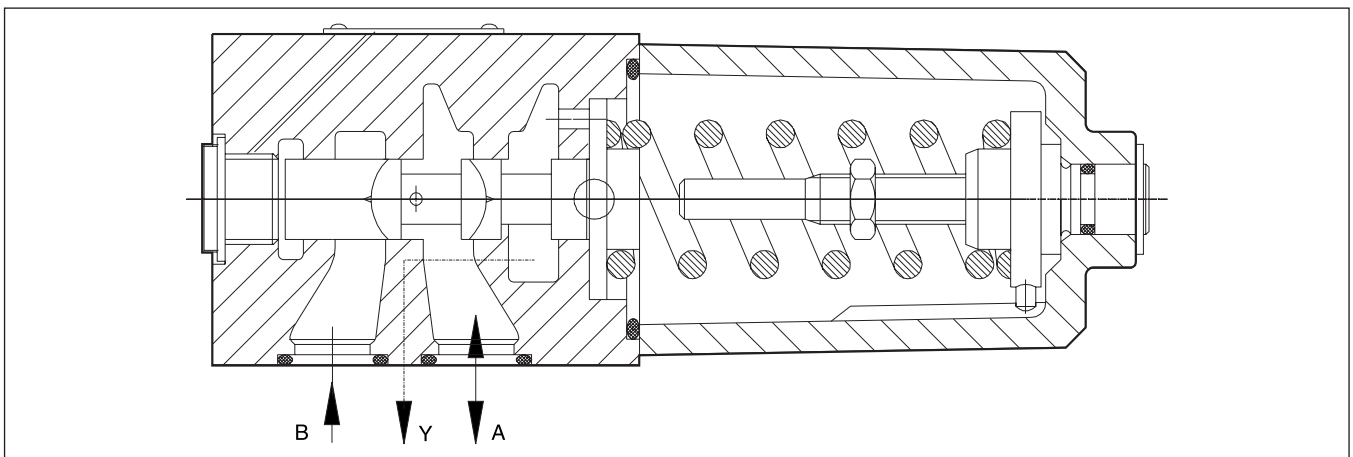

VM_UK.INDD CM

Ordering Code / Technical Data

Ordering code

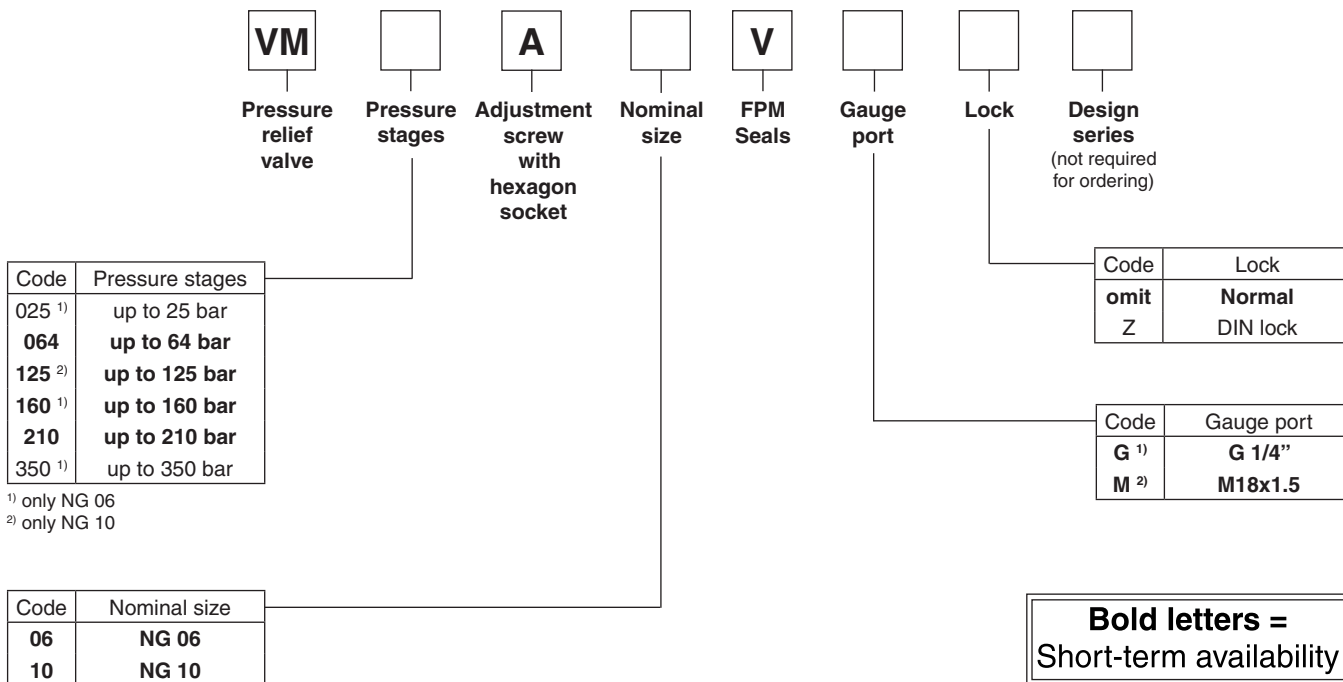

Technical data

General		Pressure reducing valve, direct operated, spool type	
Design		Pressure reducing valve, direct operated, spool type	
Nominal size		NG 06 (CETOP 03 / NFPA D03)	NG 10 (CETOP 05 / NFPA D05)
Interface		Subplate mounting according to ISO 5781	
Mounting position		unrestricted	
Ambient temperature	[°C]	-20...+80	
Weight	[kg]	1.3	3.7
Hydraulics			
Max. operating pressure	[bar]	Port P and A 350 Port T depressurized	Port A and B 210 Port Y depressurized
Pressure stages	[bar]	25; 64; 160; 210; 350	64; 125; 210
Nominal flow	[l/min]	25	60
Fluid		Hydraulic oil according to DIN 51524...525	
Fluid temperature	[°C]	-20...+70	
Viscosity recommended	[cSt] / [mm ² /s]	30...50	
Viscosity permitted	[cSt] / [mm ² /s]	20...380	
Filtration		ISO 4406 (1999); 18/16/13	

NG06

Setting pressure max. 25 bar

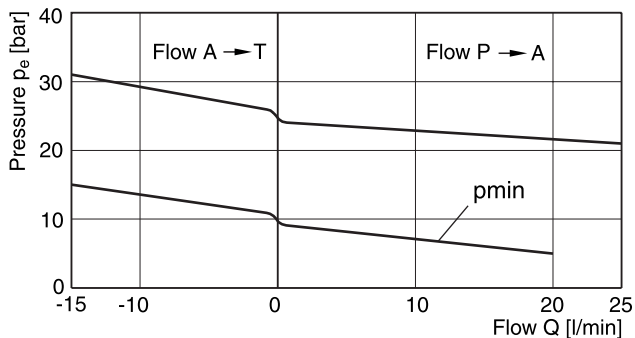

Setting pressure max. 160 or 210 bar

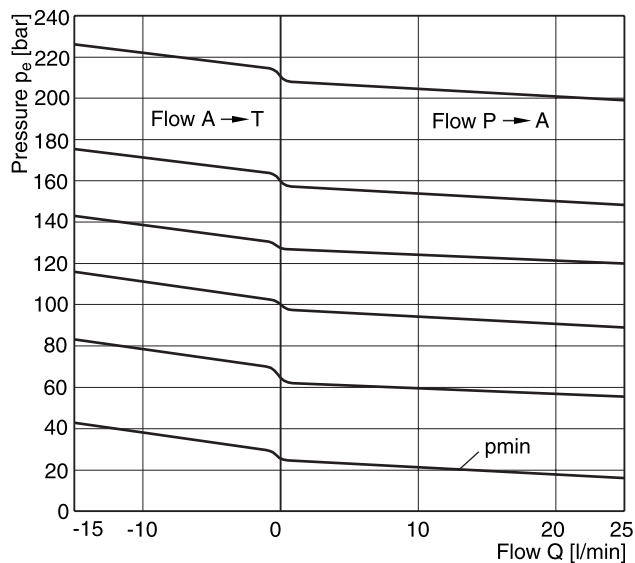

Setting pressure max. 64 bar

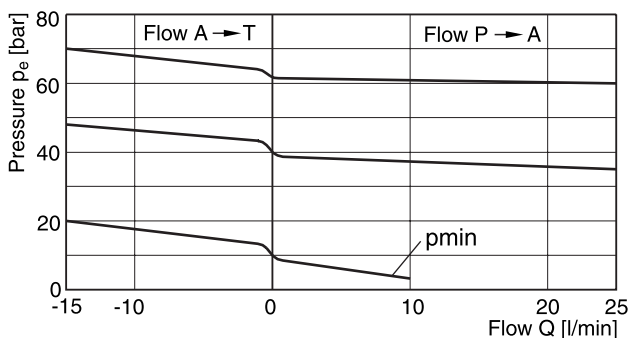

NG10

Setting pressure max. 64 bar

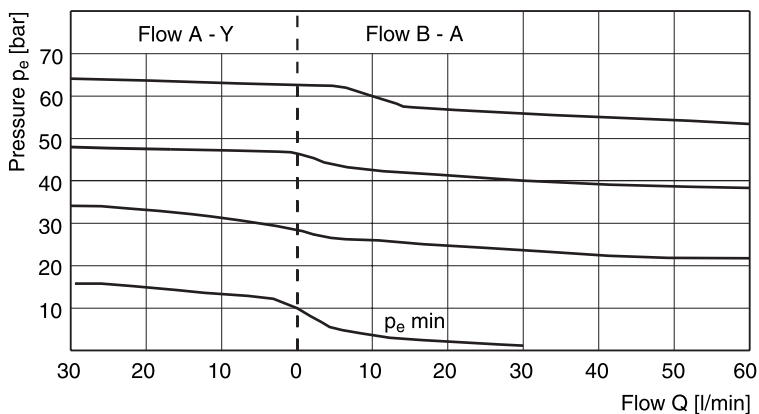

Setting pressure max. 210 bar

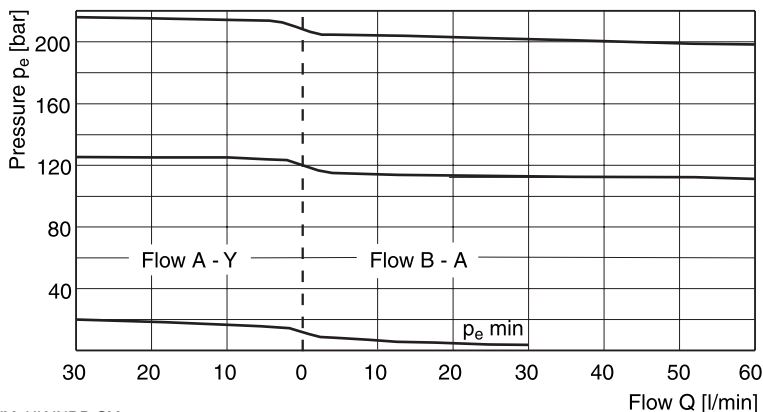

VM_UK.INDD CM

4

NG06

4

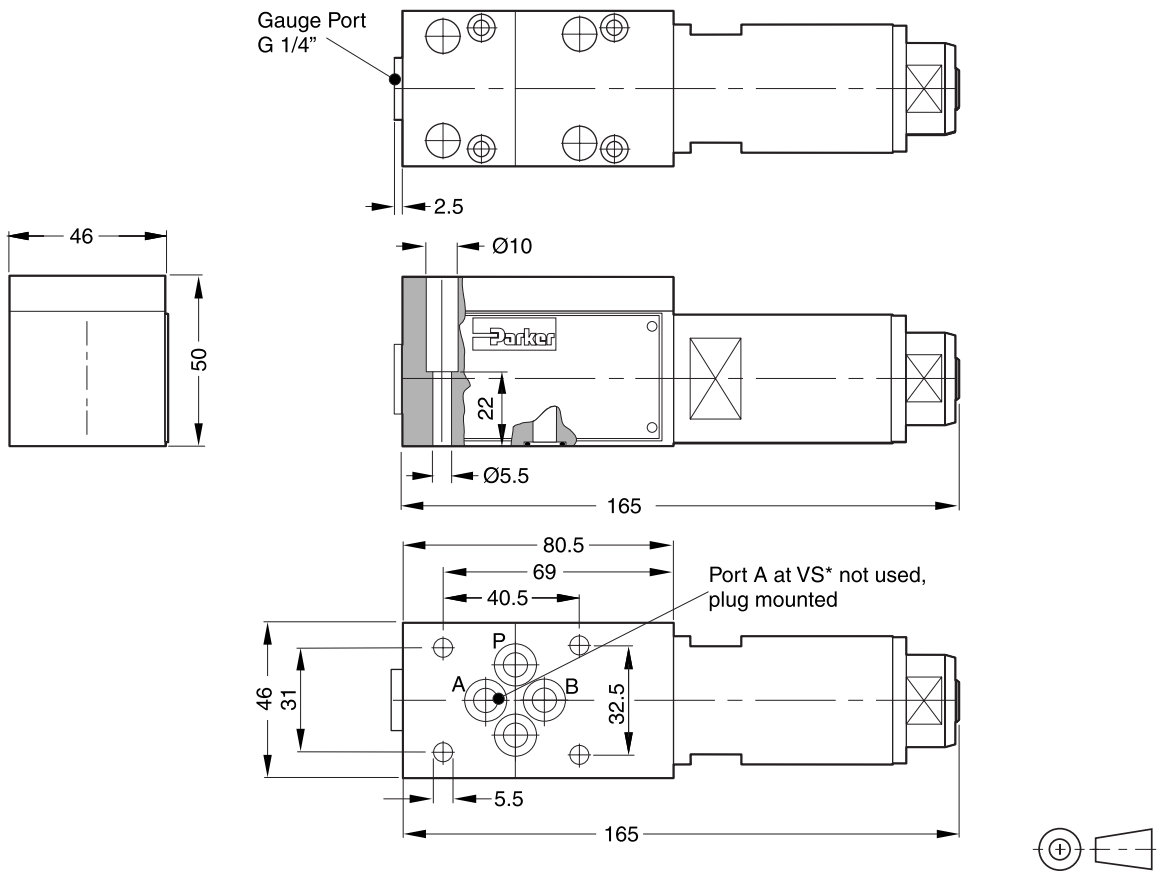



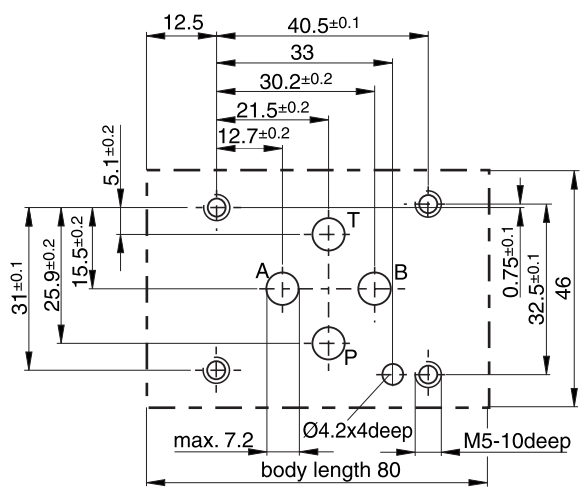

Surface finish 	Bolt kit DIN 912 12.9		Kit FPM
	BK-M5x30-4pcs	7.6 Nm ±15%	SK-VB/VM/VS-A06V

Mounting pattern ISO 5781-03-04-0-00

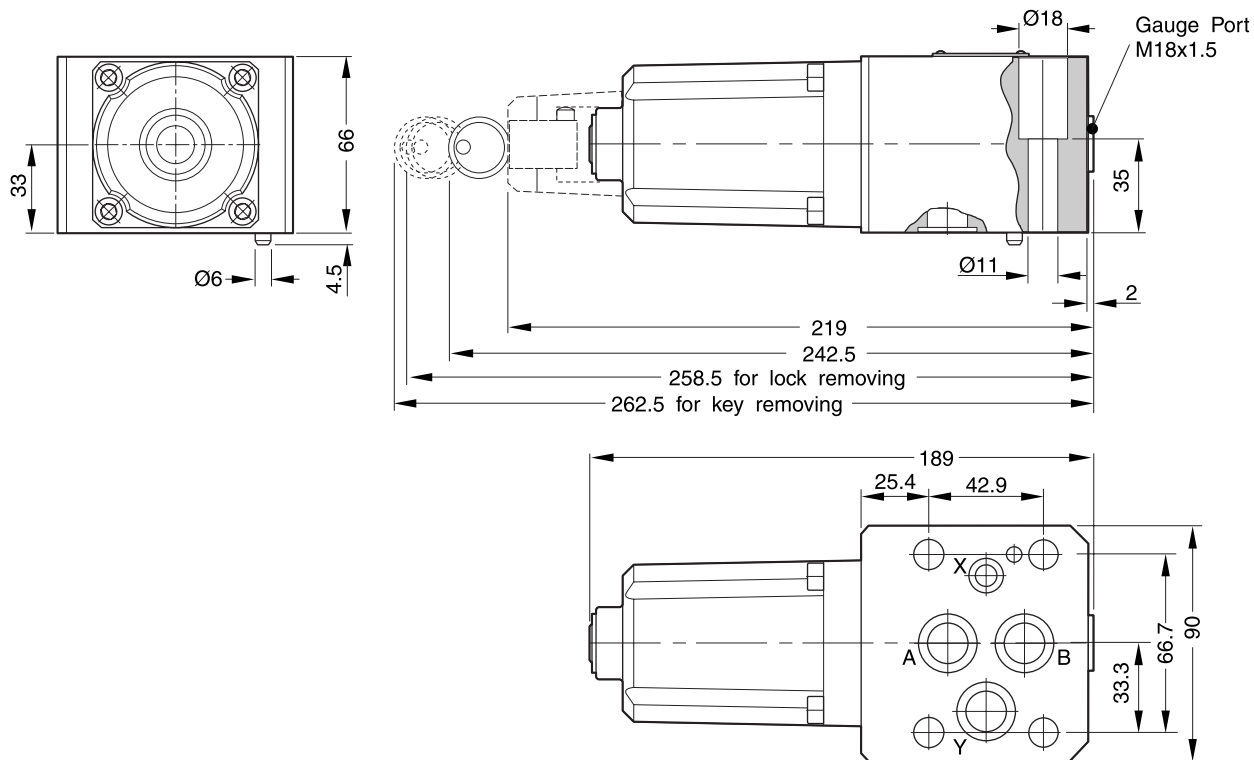

NG10

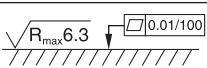

Surface finish	Bolt kit  DIN 912 12.9		 Kit FPM
	BK-M10x50-4pcs	63 Nm ±15%	SK-VB/VM-A10V

Mounting pattern ISO 5781-06-07-0-00

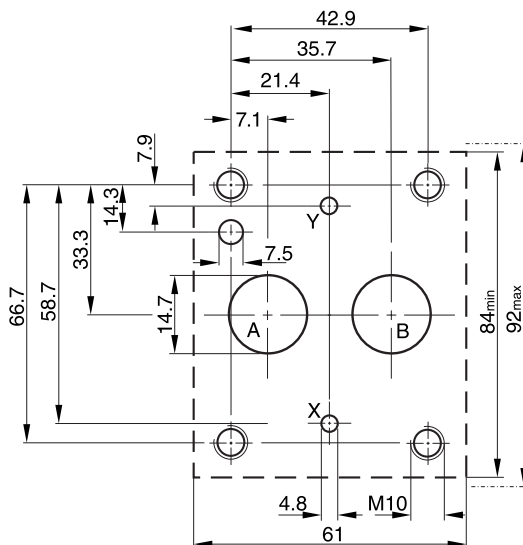

VM_UK.INDD CM



Subplate mounted pressure reducing valves are available with both Parker (series PR) and Denison (series R4R) model codes.

These valves are used to control the pressure in the secondary part of the hydraulic system. Independent of the primary pressure the secondary pressure is reduced to the pressure setting. In order to avoid undesired motion the valves are normally closed.

Features

- Pilot operated with manual adjustment
- Subplate mounting acc. to ISO 5781
- Normally closed to avoid unintended motion
- 4 pressure stages
- 3 adjustment modes
 - hand knob
 - acorn nut with lead seal
 - DIN lock

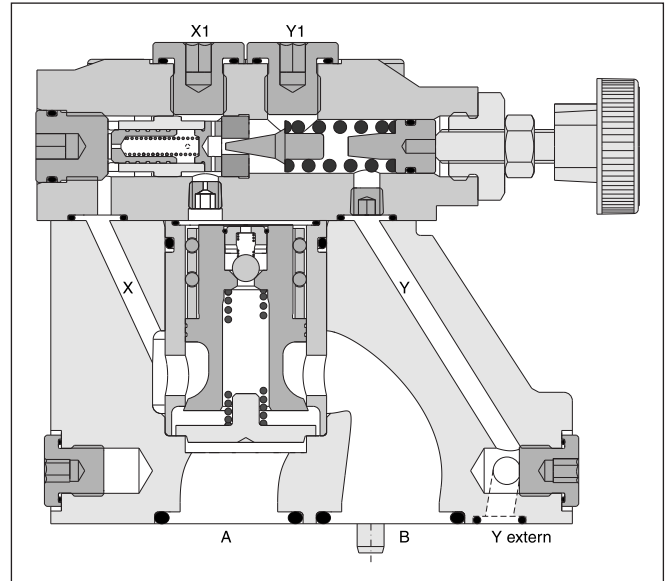
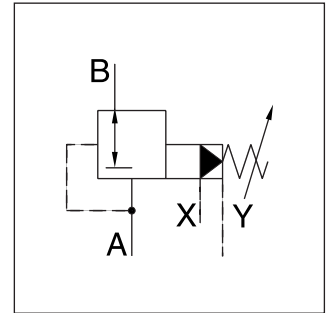

4

Technical data

General				
		10	25	32
Nominal size				
Interface		Subplate mounting acc. ISO 5781		
Mounting position		as desired, horizontal mounting preferred		
Ambient temperature	[°C]	-20...+80		
Weight	[kg]	4.8	7.2	13.5
Hydraulic				
Max. operating pressure	[bar]	Ports A, B and X 350, port Y depressurized		
Pressure stages	[bar]	105, 175, 250, 350 (series PR), 105, 210, 350 (series R4R)		
Nominal flow	[l/min]	150	350	650
Fluid		Hydraulic oil according to DIN 51524 ... 525		
Viscosity, recommended permitted	[cSt] / [mm²/s]	30 ... 50		
	[cSt] / [mm²/s]	20 ... 380		
Fluid temperature	[°C]	-20 ... +70		
Filtration		ISO 4406 (1999); 18/16/13		

Parker

4

PR		M			1	P		9	
Pressure reducing valve	Nominal size	Interface	Pressure stages	Adjustment	Pilot oil: external drain	Poppet spring	Seals	Normally closed	Design series <small>(not required for ordering)</small>

Code	Nominal size
10	NG10
25	NG25
32	NG32

Code	Seals
N	NBR
V	FPM

Code	Adjustment
S	Hand knob (Standard)
L	DIN lock
A	Acorn nut with lead seal

Code	Pressure stages
10	up to 105 bar
17	up to 175 bar
25	up to 250 bar
35	up to 350 bar

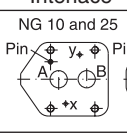
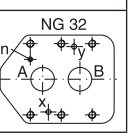
Code	Interface
M	Subplate mounting ISO 5781
	<div style="display: flex; justify-content: space-around;"> <div style="text-align: center;"> <small>NG 10 and 25</small>  </div> <div style="text-align: center;"> <small>NG 32</small>  </div> </div>



The Parker model code should be used for all new applications. Otherwise also refer to Denison model code.

Denison

R	4	R		5	9			B		
Pressure valve	Interface	Reducing function	Nominal size	Pilot ports G1/4"	Pressure stages	Adjustment	Pilot oil	Design series	Seals	Modifications

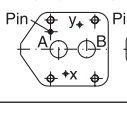
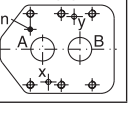
Code	Interface
4	Subplate mounting ISO 5781
	<div style="display: flex; justify-content: space-around;"> <div style="text-align: center;"> <small>NG 10 and 25</small>  </div> <div style="text-align: center;"> <small>NG 32</small>  </div> </div>

Code	Nominal size
03	NG10
06	NG25
10	NG32

Code	Pressure stages
1	up to 105 bar
3	up to 210 bar
5	up to 350 bar

Code	Seals
1	NBR
5	FPM

Pilot oil		
Code	Pilot	Drain
1	Internal	External from Y
2	Internal	Internal from Y1

Code	Adjustment
1	Hand knob 32mm dia. (Standard)
3	Acorn nut with lead seal
4	DIN lock



The Denison model code is available for existing applications. Otherwise also refer to Parker model code.

Reduced pressure pA versus flow Q

PR10M ¹⁾

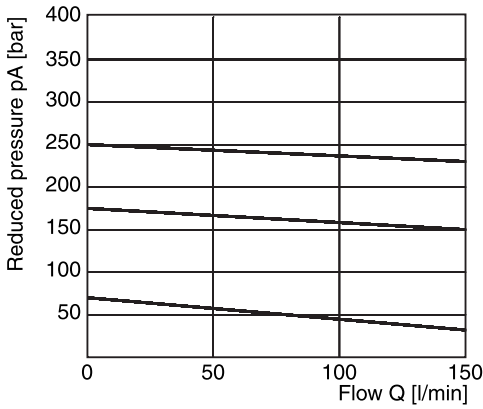

Minimum pressure curve

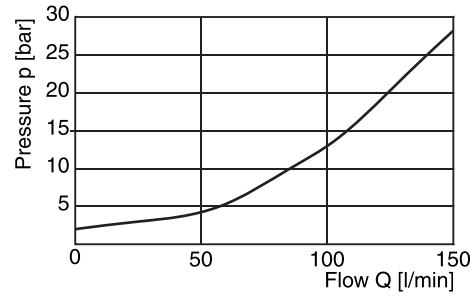

Reduced pressure pA versus flow Q

PR25M ¹⁾

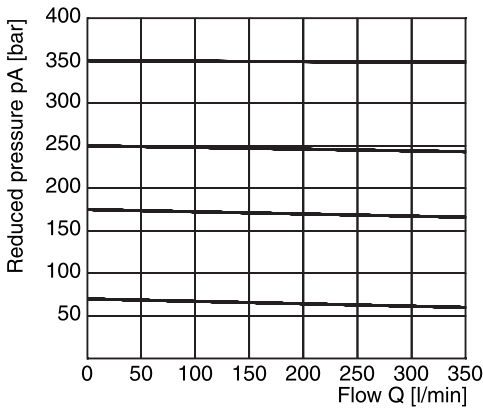

Minimum pressure curve

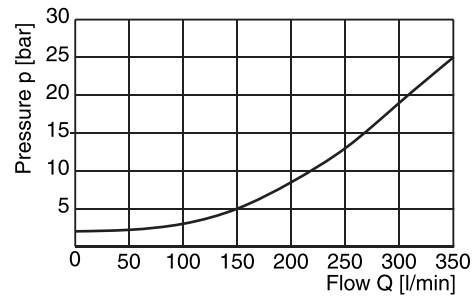

Reduced pressure pA versus flow Q

PR32M ¹⁾

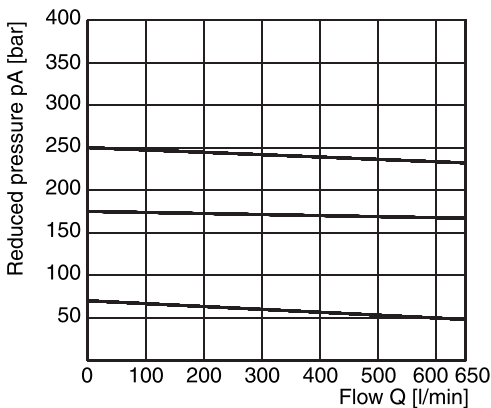

Minimum pressure curve

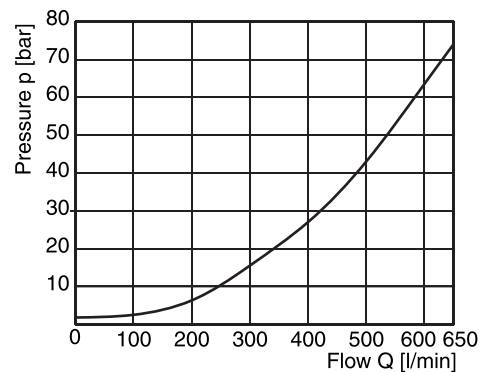

¹⁾ Measured at 350 bar primary pressure pB.

PR*M

4

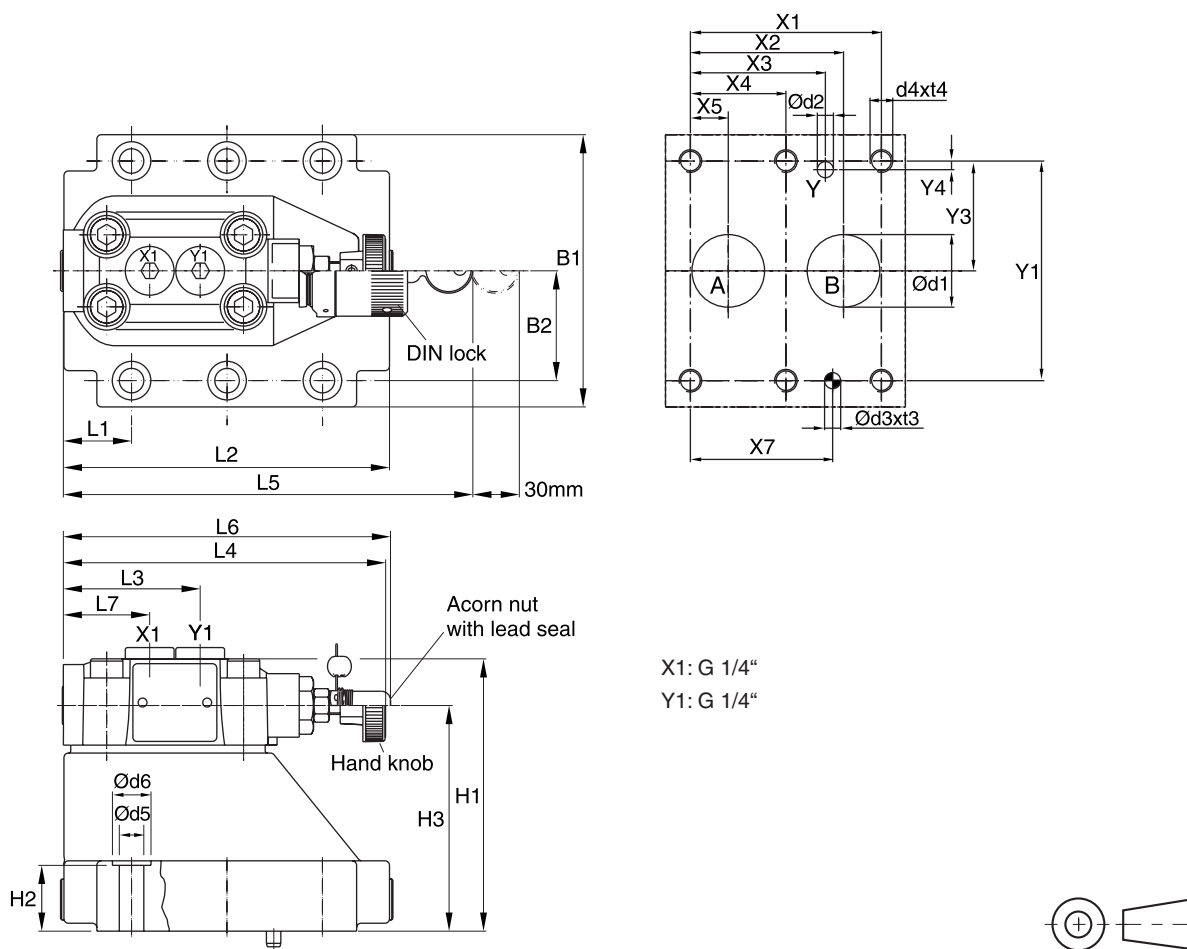

NG	ISO-code	x1	x2	x3	x4	x5	x6	x7	y1	y2	y3	y4	y5	y6
10	5781-06-07-0-00	42.9	35.8	21.5	-	7.2	-	31.8	66.7	-	33.4	7.9	-	-
25	5781-08-10-0-00	60.3	49.2	39.7	-	11.1	-	44.5	79.4	-	39.7	6.4	-	-
32	5781-10-13-0-00	84.2	67.5	59.5	42.1	16.7	-	62.7	96.8	-	48.4	3.8	-	-

Tolerance for all dimensions ±0.2

NG	ISO-code	B1	B2	H1	H2	H3	H4	H5	H6	L1	L2	L3	L4	L5	L6	L7
10	5781-06-07-0-00	87.3	33.35	83	21	62.5	-	-	-	29	94.8	60.8	143	181	144.8	38.6
25	5781-08-10-0-00	105	39.7	109.5	29	89	-	-	-	34.7	126.8	60.8	143	181	144.8	38.6
32	5781-10-13-0-00	120	48.4	120	29	99.5	-	-	-	30.6	144.3	60.8	143	181	144.8	38.6

NG	ISO-code	d1max	d2max	d3	t3	d4	t4	d5	d6
10	5781-06-07-0-00	15	7	7.1	8	M10	16	10.8	17
25	5781-08-10-0-00	23.4	7.1	7.1	8	M10	18	10.8	17
32	5781-10-13-0-00	32	7.1	7.1	8	M10	20	10.8	17

NG	ISO-code	Bolt kit - DIN912 12.9		Kit		Surface finish
				NBR	FPM	
10	5781-06-07-0-00	BK-M10 x 35-4pcs	63 Nm ±15%	SK-PR10MN50	SK-PR10MV50	
25	5781-08-10-0-00	BK-M10 x 45-4pcs	63 Nm ±15%	SK-PR25MN50	SK-PR25MV50	
32	5781-10-13-0-00	BK-M10 x 45-6pcs	63 Nm ±15%	SK-PR32MN50	SK-PR32MV50	

PR-R4R_UK.INDD CM

Proportional pressure reducing valves of the series VMY allow the variable adjustment of the reduced pressure from 0 bar up to the nominal pressure.

The valve consists of a spool type main stage and a proportionally operated pilot stage. The desired pressure can be variably set corresponding to the command signal specified on the amplifier. The proportional solenoid converts the current of the amplifier into force on the valve poppet of the pilot stage.

Typical applications are pressure systems, test equipment, or counterweight systems.

The optimum performance can be achieved in combination with the digital amplifier module PCD00A-400 for open loop systems or with PWDXXA-40* for closed loop systems.

Function

With the proportional solenoids de-energized the main spring forces the main spool into the neutral position. Port A is connected to port T. Thus the reduced pressure only depends on the back pressure in the external drain pipe and/or the tank pressure and can accordingly be reduced down to 0 bar. The pressure present in the P line delivers the pilot oil to the pilot stage via a flow control valve.

When the proportional solenoid is energized, the pilot pressure is increased in the pilot pressure area, and the main spool moves against the spring until the connection P - A opens. The regulation of the reduced pressure on connection A takes place by the constant comparison of the actual pressure and the reference pressure of the pilot stage.

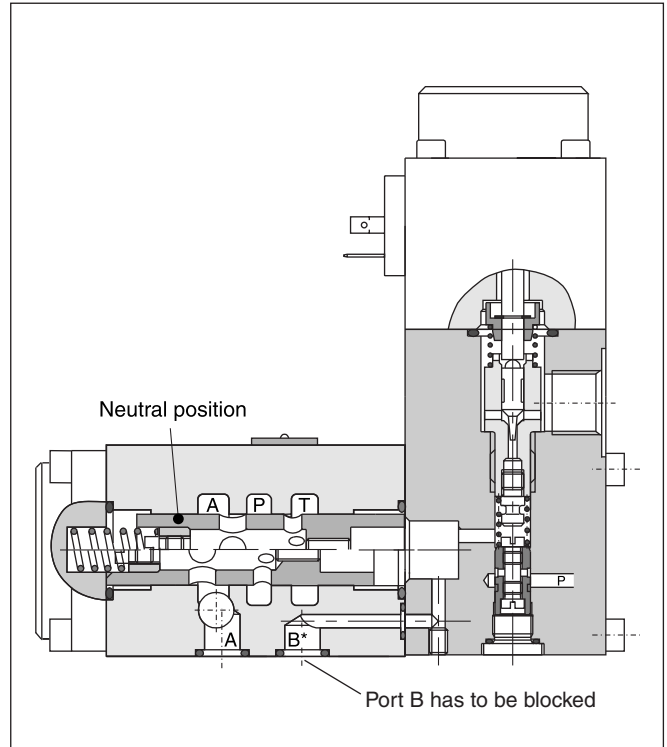
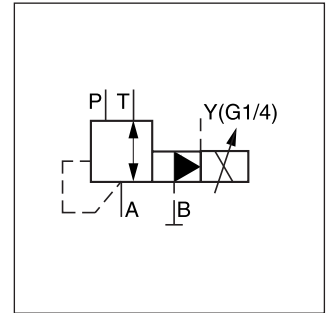

4

Ordering code

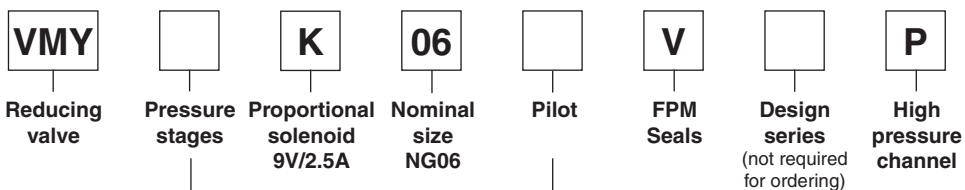

Code	Pressure stages
064	up to 64 bar
100	up to 100 bar
160	up to 160 bar
210	up to 210 bar
315	up to 315 bar

Pilot oil		
Code	Pilot	Drain
N ¹⁾	Internal	External ²⁾
T	Internal	Internal

¹⁾ connection on port Y
²⁾ pmin = 0 bar possible

Bold letters = Short-term availability

Technical Data

General		
Design		3 way proportional reducing valve, pilot operated, spool design
Nominal size		06 (DIN NG06 / CETOP 03 / NFPA D03)
Interface		Subplate mounting according to ISO 5781
Actuation		Proportional solenoid
Mounting position		unrestricted
Ambient temperature	[°C]	-20 ... +80
Weight	[kg]	2.8
Hydraulics		
Max. operating pressure	[bar]	Ports P, A 315; Port T, Y depressurized; port B has to be blocked
Pressure stages	[bar]	64, 100, 160, 210, 315
Nominal flow	[l/min]	40
Fluid		Hydraulic oil as per DIN 51 524 ... 535
Viscosity recommended	[cSt] / [mm²/s]	30 ... 50
permitted	[cSt] / [mm²/s]	20 ... 380
Fluid temperature	[°C]	-20 ... +70
Filtration		ISO 4406 (1999); 18/16/13
Linearity	[%]	See characteristic pressure curves
Repeatability	[%]	<±2
Hysteresis	[%]	±1.5 to pmax
Response time	[ms]	<150
Electrical		
Duty ratio	[%]	100 ED
Protection class		IP65 in accordance with EN 60529 (plugged and mounted)
Nominal voltage	[VDC]	9
Max. current	[A]	2.7
Ambient temperature	[°C]	-20...+70
Coil resistance	[Ohm]	-2.1 (at 20°C)
Solenoid connection		Connector as per EN 175301-803
Power amplifier, recommended		PCD00A-400

4

Characteristic pressure lines $p = f(U_{set})$

Setting range max. 64 bar

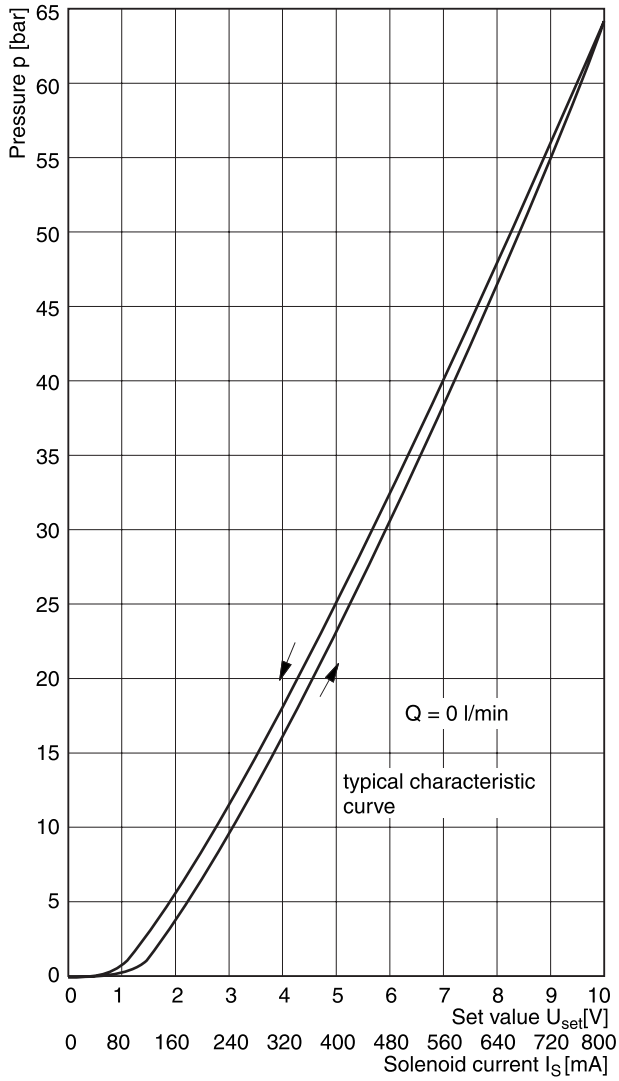

Setting range max. 210 bar

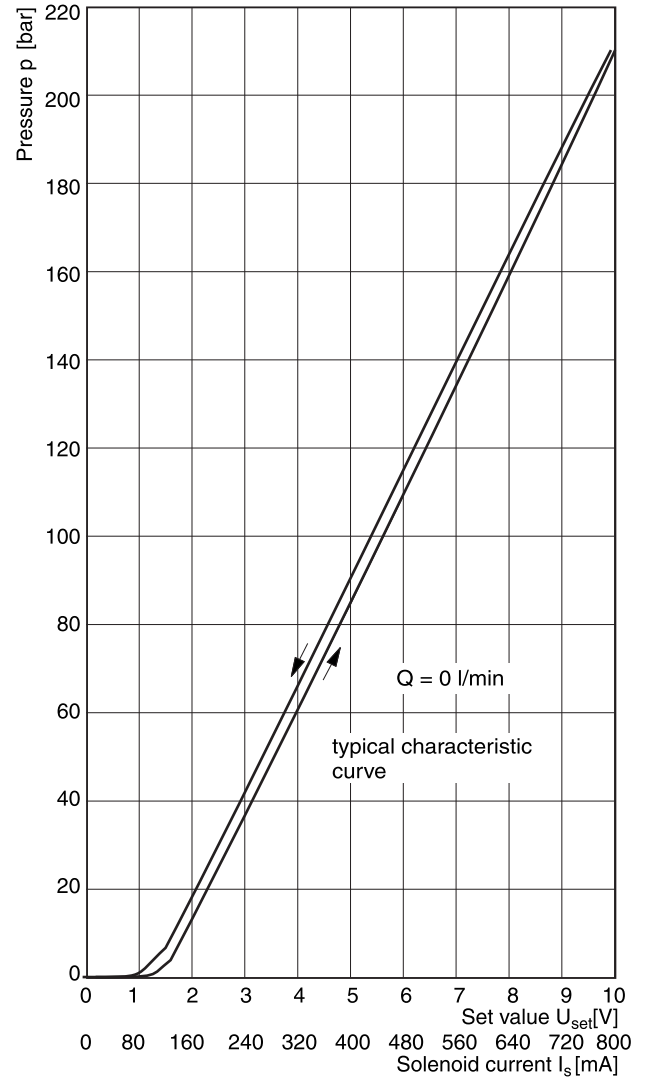

4

p/Q characteristics

measured at $t = 50^{\circ}\text{C}$ and $v = 0.35 \text{ mm}^2/\text{s}$

Setting range max. 64 bar

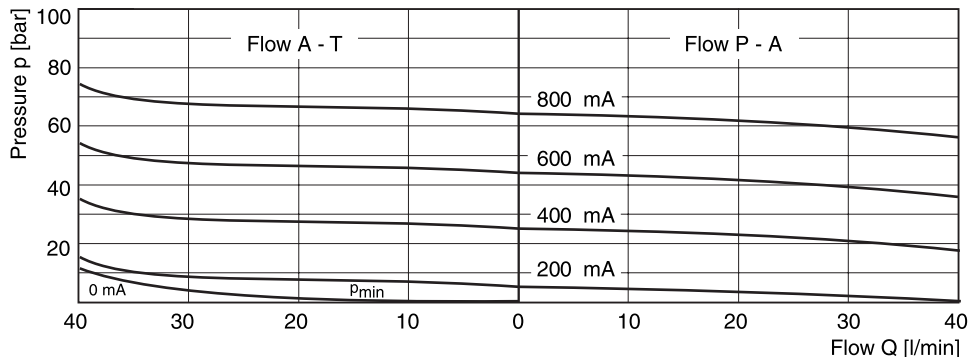

Setting range max. 100 bar

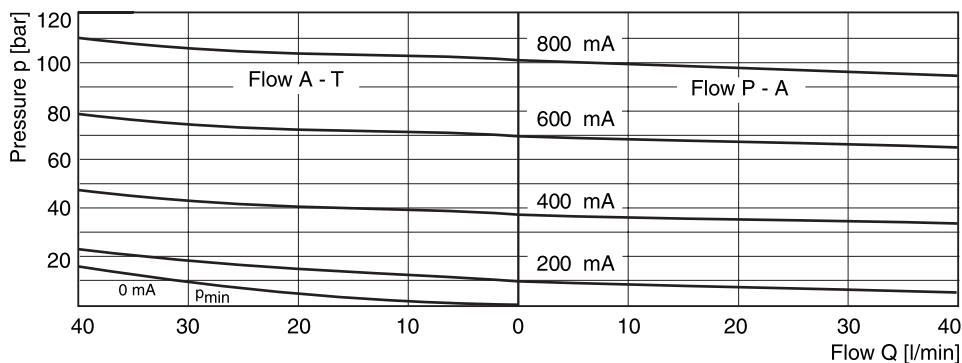

Setting range max. 160 bar

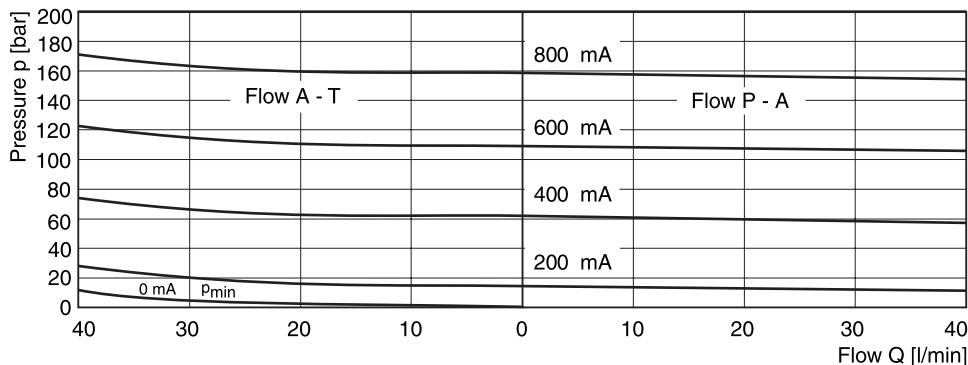

Setting range max. 210 bar

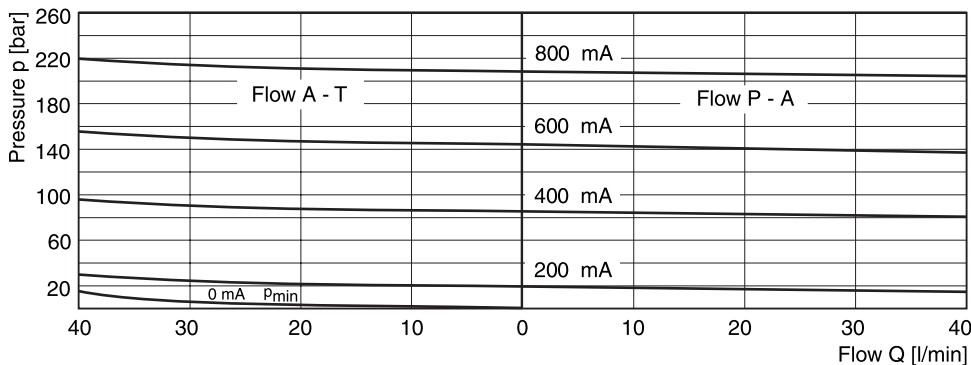

VMY_UK.INDD CM

4

p/Q characteristics

measured at $t = 50^{\circ}\text{C}$ and $v = 0.35 \text{ mm}^2/\text{s}$

Setting range max. 315 bar

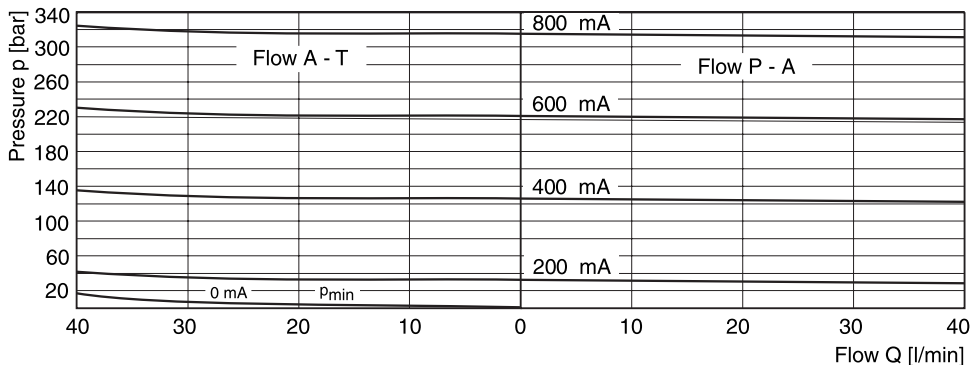

4

Step response

Typical curve

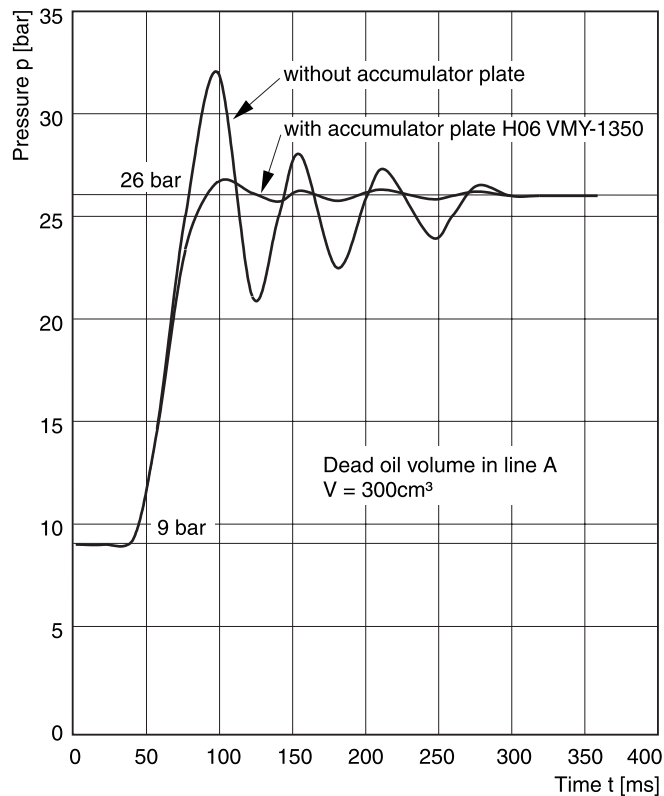
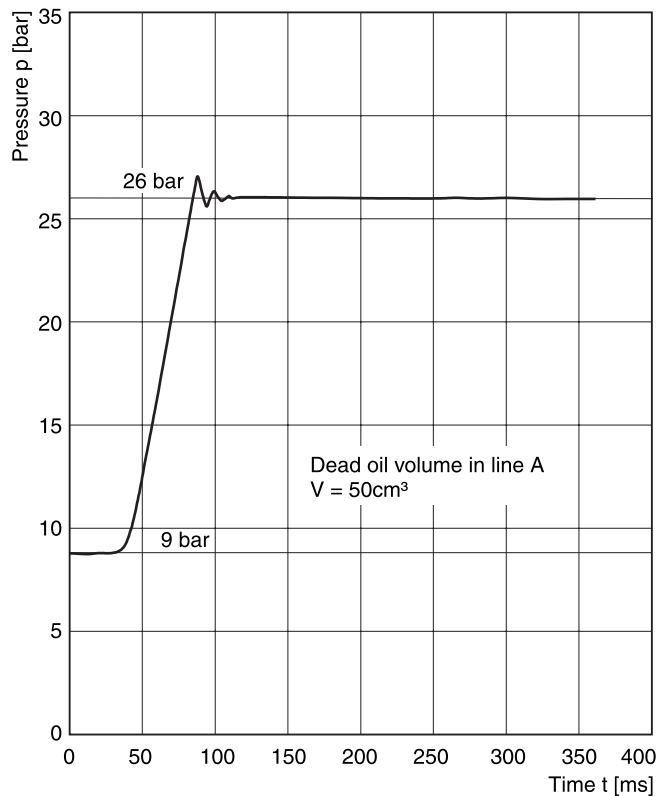

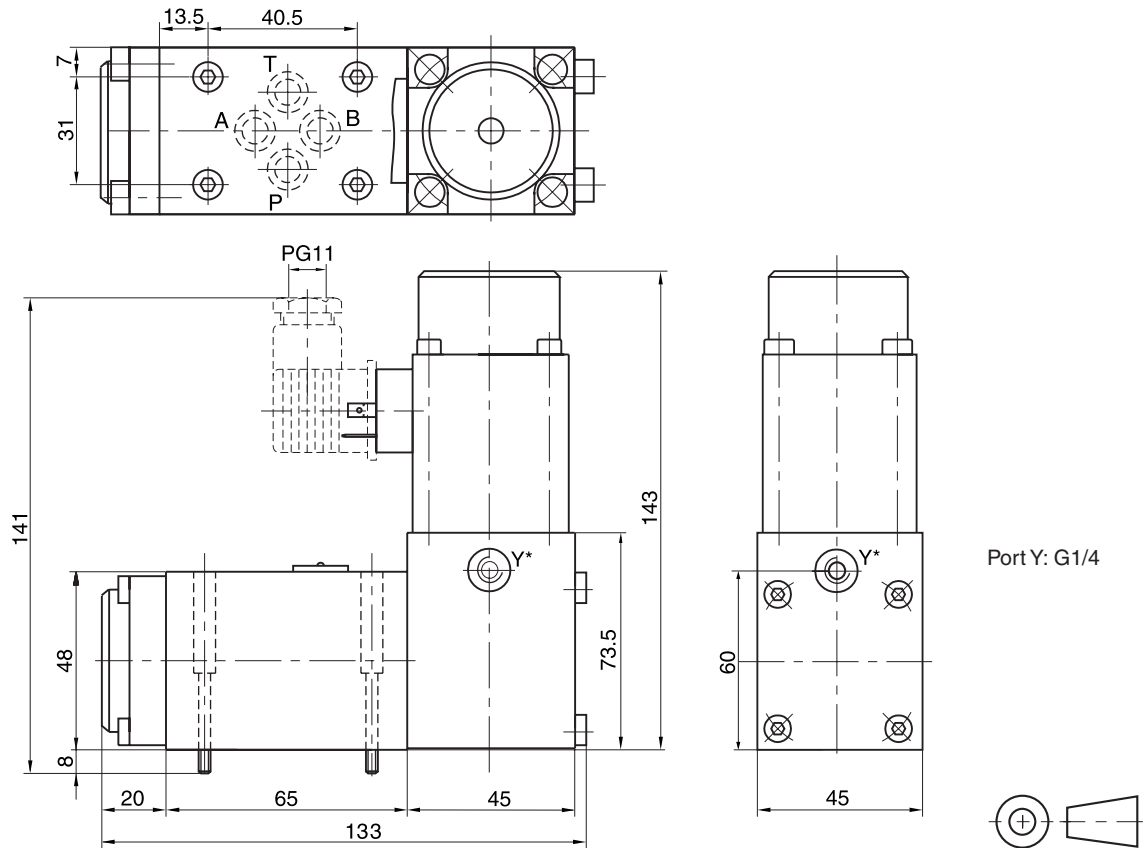

4

Surface finish 	Bolt kit DIN 912 12.9		Kit FPM
	BK-M5x30-4pcs	7.6 Nm ±15%	SK-VMY-L06-V

Mounting pattern ISO 5781-03-04-0-00

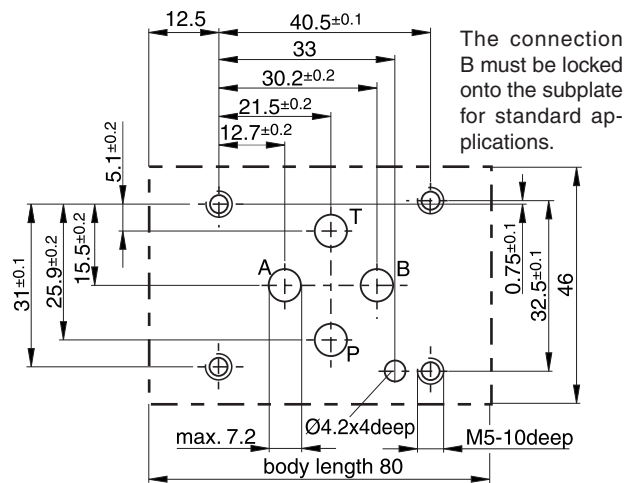

Subplate mounted proportional pressure reducing valves are available with both Parker (series PE*W) and Denison (series R4R) model codes.

These valves have a proportional solenoid operated pilot stage and a cartridge main stage.

The optimum performance can be achieved in combination with the digital amplifier module PCD00A-400.

Features

- Pilot operated with proportional solenoid
- Continuous adjustment by proportional solenoid
- Subplate mounting according to ISO 5781
- 4 pressure stages
- Mechanical maximum pressure adjustment

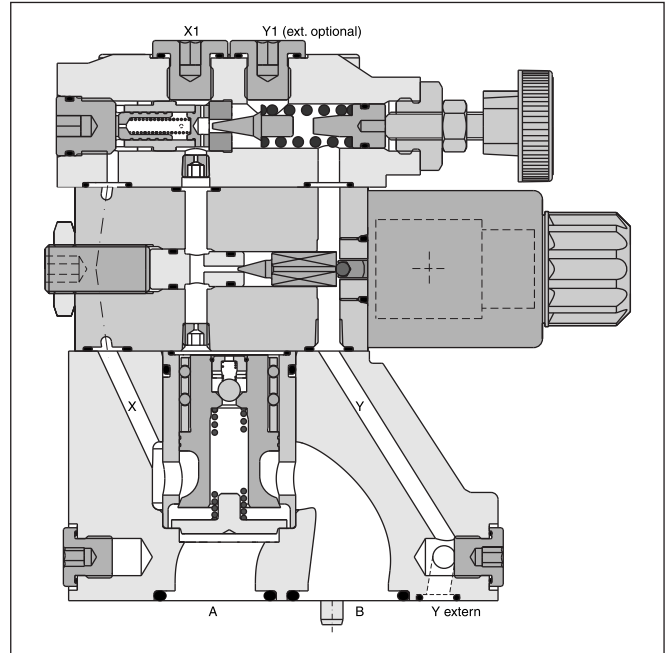
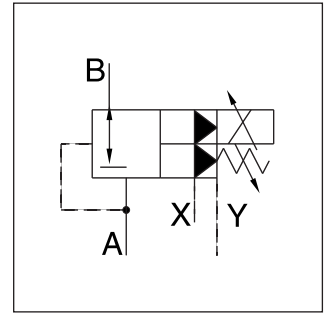

4

Technical data

General				
		10	25	32
Nominal size				
Interface		Subplate mounting acc. ISO 5781		
Mounting position		as desired, horizontal mounting preferred		
Ambient temperature	[°C]	-20...+80		
Weight	[kg]	2.7	4.5	6.0
Hydraulic				
Max. operating pressure	[bar]	Ports A and X 350, ports B and Y depressurized		
Pressure stages	[bar]	105, 250, 350		
Nominal flow	[l/min]	150	350	650
Fluid		Hydraulic oil according to DIN 51524 ... 525		
Viscosity recommended	[cSt] / [mm²/s]	30 ... 50		
permitted	[cSt] / [mm²/s]	20 ... 380		
Fluid temperature	[°C]	-20 ... +70		
Filtration		ISO 4406 (1999); 18/16/13		
Electrical				
Duty ratio	[%]	100 ED		
Protection class		IP65 in accordance with EN 60529 (plugged and mounted)		
Nominal voltage	[V]	12		
Max. current	[A]	2.3		
Coil resistance	[Ohm]	4 at 20°C		
Solenoid connection		Connector as per EN 175301-803		
Power amplifier, recommended		PCD00A-400		

PEW-R4R_UK.INDD CM



Parker

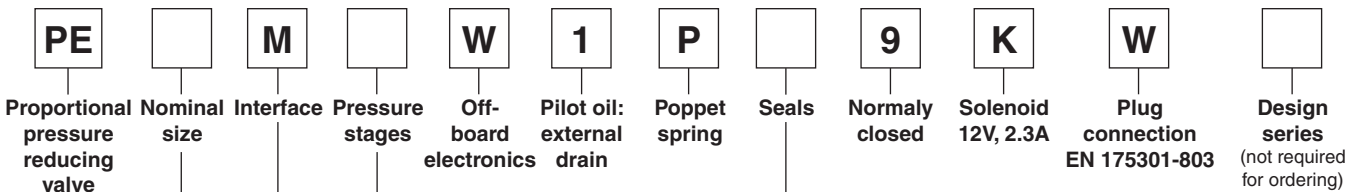

Code	Nominal size
10	NG10
25	NG25
32	NG32

Code	Seals
N	NBR
V	FPM

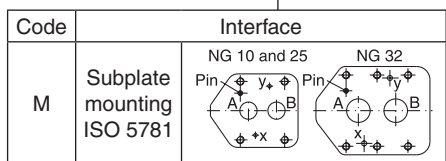

Code	Pressure stages
10	up to 105 bar
21	up to 210 bar
35	up to 350 bar

The Parker model code should be used for all new applications. Otherwise also refer to Denison model code.

Denison

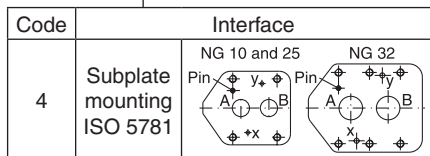
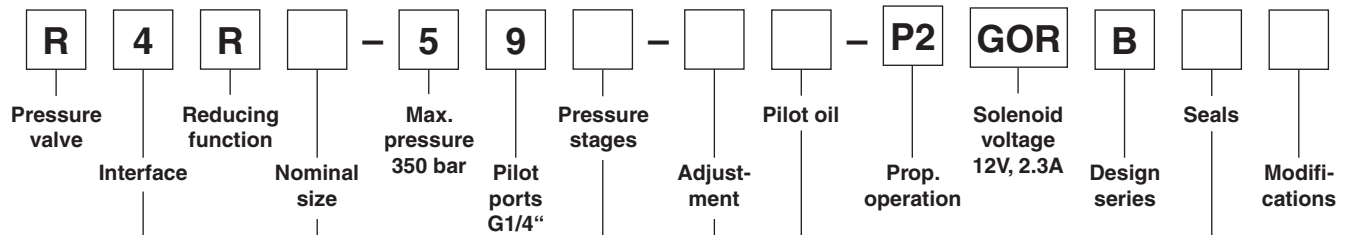

Code	Seals
1	NBR
5	FPM

Code	Nominal size
03	NG10
06	NG25
10	NG32

Pilot oil		
Code	Pilot	Drain
1	Internal	External from Y
2	Internal	External from Y1

Code	Pressure stages
1	up to 105 bar
3	up to 210 bar
5	up to 350 bar

Code	Adjustment
1	Hand knob 32mm dia. (Standard)
3	Acorn nut with lead seal

The Denison model code is available for existing applications. Otherwise also refer to Parker model code.

4

Command/pressure curve

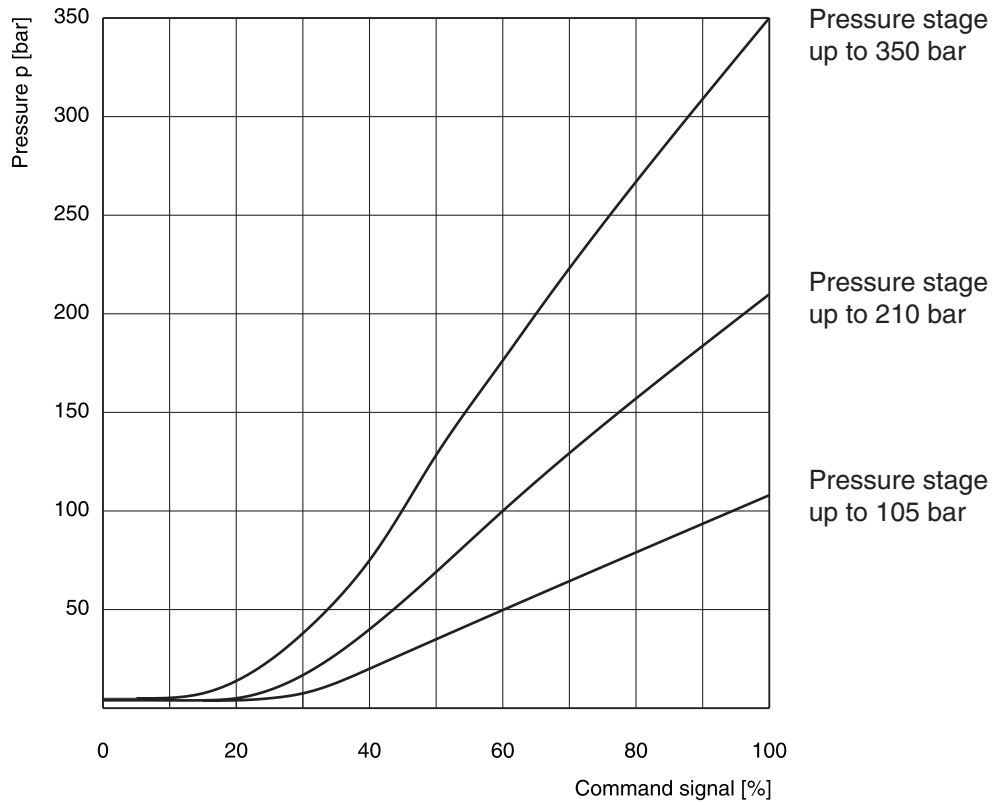

Reduced pressure pA versus flow Q

PE10M*W / R4R03 ¹⁾

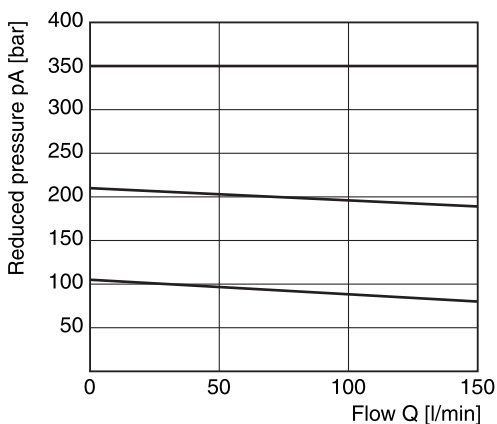

Minimum pressure curve

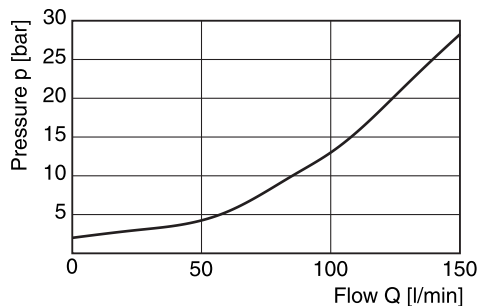

Reduced pressure pA versus flow Q

PE10M*W / R4R06 ¹⁾

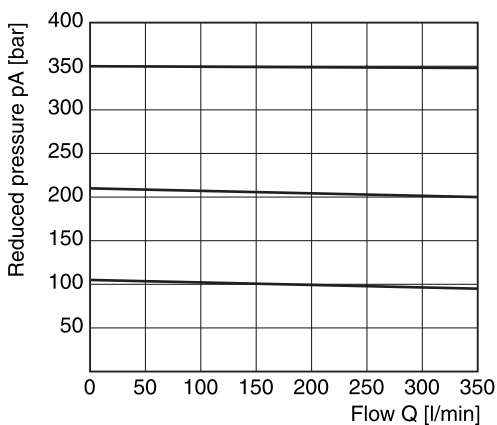

Minimum pressure curve

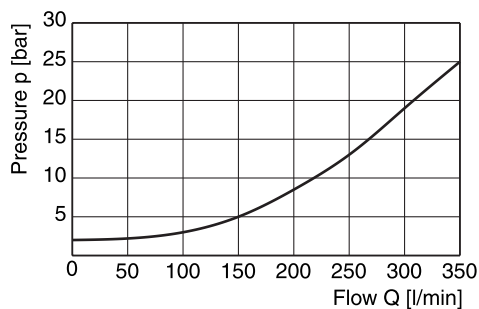

Reduced pressure pA versus flow Q

PE10M*W / R4R10 ¹⁾

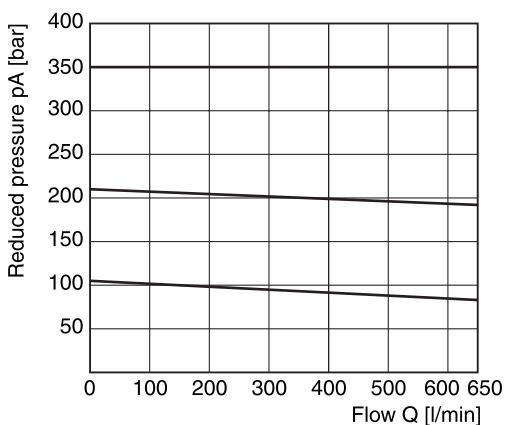

Minimum pressure curve

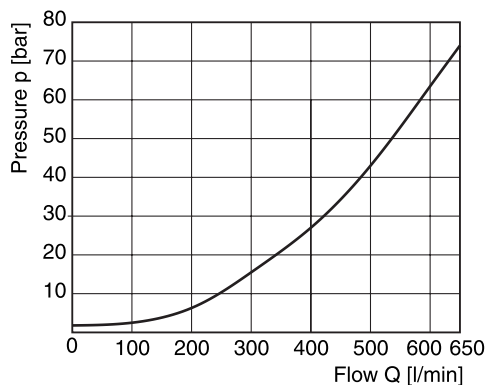

¹⁾ Measured at 350 bar primary pressure pB.

4

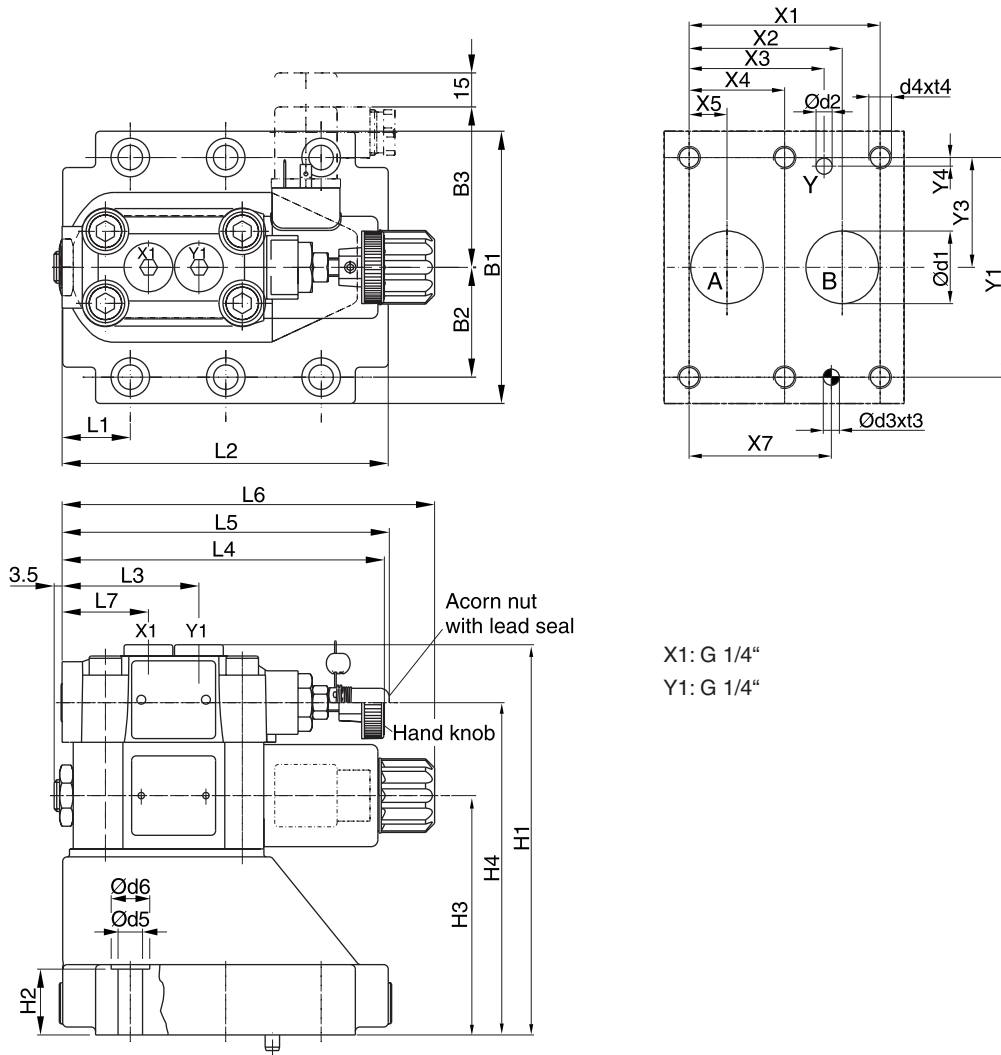

4

NG	ISO-code	x1	x2	x3	x4	x5	x6	x7	y1	y2	y3	y4	y5	y6
10	5781-06-07-0-00	42.9	35.8	21.5	–	7.2	–	31.8	66.7	–	33.4	7.9	–	–
25	5781-08-10-0-00	60.3	49.2	39.7	–	11.1	–	44.5	79.4	–	39.7	6.4	–	–
32	5781-10-13-0-00	84.2	67.5	59.5	42.1	16.7	–	62.7	96.8	–	48.4	3.8	–	–

Tolerance for all dimensions ±0.2

NG	ISO-code	B1	B2	B3	H1	H2	H3	H4	L1	L2	L3	L4	L5	L6	L7
10	5781-06-07-0-00	87.3	33.35	71	134	21	68.5	109.5	29	94.8	60.8	143	144.8	164.8	38.6
25	5781-08-10-0-00	105	39.7	71	160.5	29	95	136	34.7	126.8	60.8	143	144.8	164.8	38.6
32	5781-10-13-0-00	120	48.4	71	171	29	105.5	146.5	30.6	144.3	60.8	143	144.8	164.8	38.6

NG	ISO-code	d1max	d2max	d3	t3	d4	t4	d5	d6
10	5781-06-07-0-00	15	7	7.1	8	M10	16	10.8	17
25	5781-08-10-0-00	23.4	7.1	7.1	8	M10	18	10.8	17
32	5781-10-13-0-00	32	7.1	7.1	8	M10	20	10.8	17

NG	ISO-code	Bolt kit - DIN912 12.9		Kit		Surface finish
				NBR	FPM	
10	5781-06-07-0-00	BK-M10 x 35-4pcs	63 Nm ±15%	SK-PE10MN50	SK-PE10MV50	$\sqrt{R_{max}6.3}$ $\square 0.01/100$
25	5781-08-10-0-00	BK-M10 x 45-4pcs	63 Nm ±15%	SK-PE25MN50	SK-PE25MV50	
32	5781-10-13-0-00	BK-M10 x 45-6pcs	63 Nm ±15%	SK-PE32MN50	SK-PE32MV50	

PEW-R4R_UK.INDD CM

Description	Threaded cable joint	Body colour coding	Figures switching	Order no.
Plug DIN 43650, design type AF, protection class IP 65 Voltages up to 250 V	PG 9	black, B grey, A	Fig. 1	5001710 5001711
	PG11	black, B grey, A	Fig. 1	5001716* 5001717*
Plug with LED insert 24 V	PG11	black, B grey, A	Fig.1 and Fig. 3	5001571 5001572
Plug with lamp insert 110 V	PG11	black, B grey, A	Fig.1 and Fig. 4	5001573 5001574
Plug with lamp insert 220 V	PG11	black, B grey, A	Fig.1 and Fig. 4	5001575 5001576
Plug with LED insert 24V and suppressing circuitry	PG11	black, B grey, A	Fig.1 and Fig. 5	5001708 5001709
Plug with rectifier. Rectifier with 4 silicon diodes in bridge circuit. Varistor in alternating current side to protect the diodes against power peaks	PG11	black, B grey, A	Fig.1 and Fig. 6	5001737 5001738
Plug with pull relief and translucent cover	PG11	black, B grey, A	Fig. 2	5001723 5001724
Application with bridge rectifier suitable for 5001723 and 5001724	—	—	Fig. 2 and Fig. 7	5001727
Application with bridge rectifier and lamp suitable for 5001723 and 5001724	—	—	Fig. 2 and Fig. 8	5001734

* If not ordered otherwise, valves with code P are supplied with these connectors.

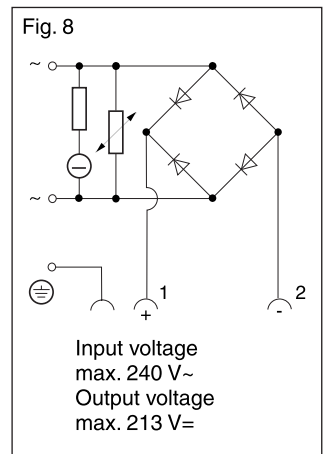
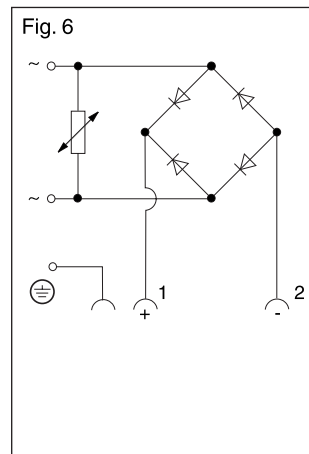
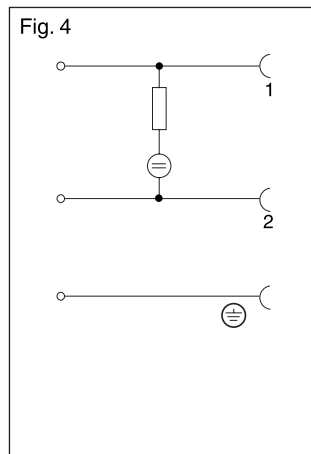
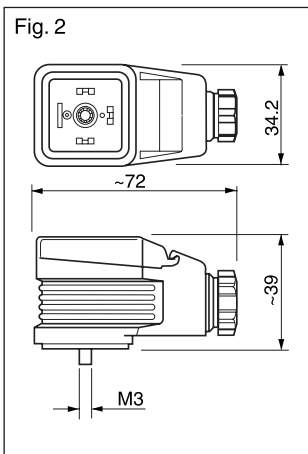
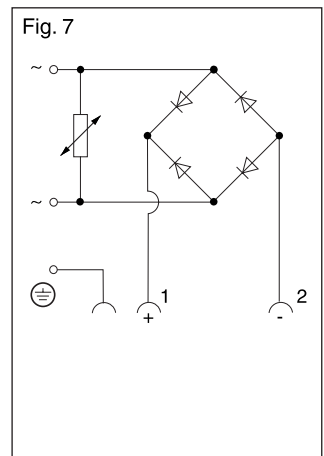
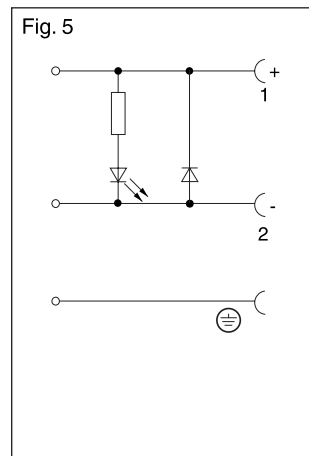
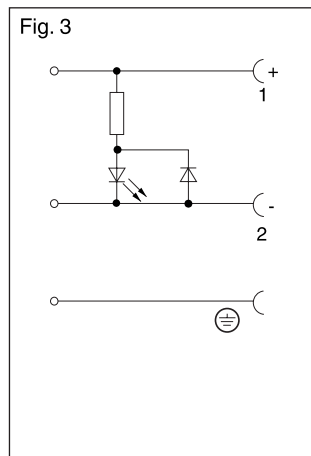
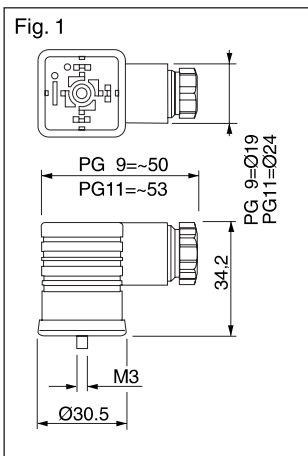

Central connector

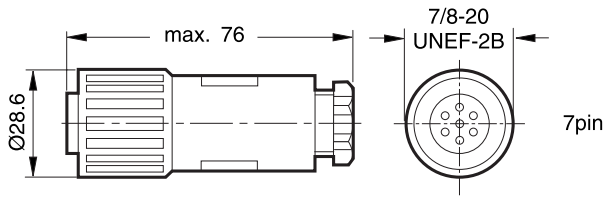

Description	Order No.
DIN 43563 6+PE	5004072